



INTERNATIONAL APPLICATION PUBLISHED UNDER THE PATENT COOPERATION TREATY (PCT)

<p>(51) International Patent Classification ⁵ : B32B 5/26, 27/02, 27/06, 27/12</p>	<p>A1</p>	<p>(11) International Publication Number: WO 94/19179 (43) International Publication Date: 1 September 1994 (01.09.94)</p>
<p>(21) International Application Number: PCT/US93/01783 (22) International Filing Date: 26 February 1993 (26.02.93)</p> <p>(71) Applicant: THE UNIVERSITY OF TENNESSEE RESEARCH CORPORATION [US/US]; 415 Communications Building, Knoxville, TN 37996-0344 (US).</p> <p>(72) Inventors: WADSWORTH, Larry, C.; 2024 Bishops Bridge Road, Knoxville, TN 37922 (US). DUCKETT, Kermit, E.; 3404 Timberlake Road, Knoxville, TN 37920 (US). BALASUBRAMANIAN, Venkataraman; Apartment 4, 131 E. North Street, Albemarle, NC 28002 (US).</p> <p>(74) Agent: WEISER, Gerard, J.; Weiser & Associates, 230 South Fifteenth Street, Suite 500, Philadelphia, PA 19102 (US).</p>	<p>(81) Designated States: CA, JP, KP, KR, European patent (AT, BE, CH, DE, DK, ES, FR, GB, GR, IE, IT, LU, MC, NL, PT, SE).</p> <p>Published <i>With international search report.</i> <i>With amended claims.</i></p>	

(54) Title: NOVEL COMPOSITE WEB

(57) Abstract

A multilayered nonwoven composite web (10) particularly useful as a substitute for a woven web such as a textile web, and having improved liquid wicking and retention properties comprising a first layer (12) of fibrous material selected from the group consisting of thermoplastic meltblown man-made fibers, thermoplastic spunbonded man-made fibers, thermoplastic man-made staple fibers and combinations thereof, this first layer being light weight, and a second layer (14) of cellulosic-based fibers, preferably cotton fibers, the first and second layers being thermally bonded (16) together over about 5 to 75% of the surface area of the web to form a coherent web having an air permeability of between about 25 and about 37 ft³/min/ft². In a preferred embodiment, the composite web includes at least a third layer of thermoplastic man-made fibers and the layer of cellulose-based fibers is sandwiched between the two layers of thermoplastic man-made fibers.

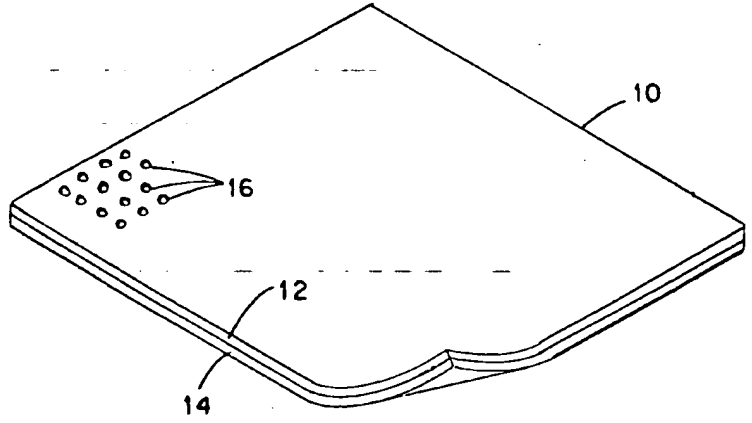

FOR THE PURPOSES OF INFORMATION ONLY

Codes used to identify States party to the PCT on the front pages of pamphlets publishing international applications under the PCT.

AT	Austria	GB	United Kingdom	MR	Mauritania
AU	Australia	GE	Georgia	MW	Malawi
BB	Barbados	GN	Guinea	NE	Niger
BE	Belgium	GR	Greece	NL	Netherlands
BF	Burkina Faso	HU	Hungary	NO	Norway
BG	Bulgaria	IE	Ireland	NZ	New Zealand
BJ	Benin	IT	Italy	PL	Poland
BR	Brazil	JP	Japan	PT	Portugal
BY	Belarus	KE	Kenya	RO	Romania
CA	Canada	KG	Kyrgyzstan	RU	Russian Federation
CF	Central African Republic	KP	Democratic People's Republic of Korea	SD	Sudan
CG	Congo	KR	Republic of Korea	SE	Sweden
CH	Switzerland	KZ	Kazakhstan	SI	Slovenia
CI	Côte d'Ivoire	LI	Liechtenstein	SK	Slovakia
CM	Cameroon	LU	Luxembourg	SN	Senegal
CN	China	LV	Latvia	TD	Chad
CS	Czechoslovakia	MC	Monaco	TG	Togo
CZ	Czech Republic	MD	Republic of Moldova	TJ	Tajikistan
DE	Germany	MG	Madagascar	TT	Trinidad and Tobago
DK	Denmark	ML	Mali	UA	Ukraine
ES	Spain	MN	Mongolia	US	United States of America
FI	Finland			UZ	Uzbekistan
FR	France			VN	Viet Nam
GA	Gabon				

NOVEL COMPOSITE WEB

This invention relates to fibrous webs and particularly to novel composite webs comprising one or more layers of a thermoplastic nonwoven web in combination with a layer of cellulosic-based fibers.

5 Nonwoven webs (fabrics) are defined as "sheet or web structures made by bonding and/or interlocking fibers, yarns or filaments by mechanical, thermal, chemical or solvent means." These webs do not require the conversion of fibers to yarn. Nonwoven webs are also called bonded or
10 engineered webs and are manufactured by processes other than spinning, weaving or knitting, hence the name "nonwovens". The basic structure of all nonwovens is a web of fibers or filaments. A single type of fiber or filament may be the basic element of a nonwoven. Fibers that are
15 measured in centimeters or inches or fractions thereof are called staple fibers. Those fibers of extreme length are called filament fibers. In general filament fibers are measured in terms of kilometers or miles. In fact, filament fibers are not readily measured, as they may be many,
20 many yards in length. In fibers the length must be considerably greater than the diameter, e.g., a length-to-width (diameter) ratio of at least 100 and usually considerably higher. Cotton fibers may measure from less than 1/2 inch to more than 2 inches in length and have a typical length-to-diameter ratio of about 1400. Other natural fibers
25 exhibit typical ratios as follows: flax - 1200; ramie - 3000; and wool - 3000. In the present application, the terms "fiber" or "fibers" are intended to include both short and long fibers, i.e. staple fibers and filament fibers, unless otherwise specifically indicated by identifying the fibers as staple or filament. For example,
30 spunbonded webs are formed of filament fibers, whereas meltblown webs include an assortment of fiber lengths so that these webs commonly include both staple length and
35 filament length fibers. In nonwovens, the individual

fibers may be in an organized or in a random arrangement. Tensile, elongation, and hand properties are imparted to the web by the type or types of bonding as well as fiber-to-fiber cohesion and reinforcement by its constituents.

5 The technology for making nonwoven webs is based on the following primary elements: fibers of various lengths and diameters; a web arranged according to the method of forming and processing; the bonding of fibers within the web and reinforcement by its constituents. The variation

10 of one or several elements in combination allows for the enormous range of nonwoven fiber types. Control of the type and length of the fibers and of the bonding, in combination with the selection of the manufacturing method, gives rise to a highly technical, yet extremely flexible

15 combination of options. Nonwoven webs have heretofore found acceptance in the medical industry as disposable substitutes for the prior art reusable cotton examination gowns, surgical gowns, surgical drapes, face masks, shoe covers, sterilization wrap and other products,

20 to the extent that this market for nonwoven products is estimated to exceed one billion dollars annually. Further, nonwoven webs have found use in sanitary products, such as sanitary napkins, disposable diapers, incontinent pads and other similar products. One of the benefits of nonwoven

25 webs heretofore has been their relatively low cost, as compared to woven webs. The difference in cost between nonwoven and woven webs has heretofore been of a magnitude such that the end users can dispose of the nonwoven web product after a single use and yet realize a monetary gain

30 over the multi-use woven webs.

Among the desired properties of a nonwoven web for use in medical and sanitary applications are the hand (softness and drapability), wicking, liquid retention, absorptive capacity and strength of the web. Also of

35 importance in acceptance of the nonwoven web by the end user is the degree to which the nonwoven web approximates the desirable properties of the woven webs, in particularly

cotton webs. Nonwoven webs generally have the reputation of notoriously lacking many of the properties of woven webs, in particular hand, wicking, and liquid absorption and retention. Meltblown nonwoven webs, for example, exhibit a void volume of about 85%; spunbonded nonwoven webs exhibit a void volume of between about 90 and 95%. These webs, further, often exhibit undesirable chemical properties, such as hydrophobicity, that make the webs less than desirable for use in medical applications, for example. Moreover, the surface properties of these nonwoven webs tend to be smooth, hence exhibit a slick or oily feel and appearance. The fibrous material of the prior art nonwoven webs most commonly exhibits a low surface tension so that aqueous liquids are not attracted thereto so that these prior art webs have poor wicking and retention of these liquids. These webs also are difficult to treat with liquid repellents. Still further, the filamentary nature of the fibers of many prior art webs and their methods of manufacture cause the fibers to lay in the webs with the length dimension of the fibers oriented substantially parallel to the plane of the web so that the webs have poor absorbency of liquids into the body of the web. Considerable effort has been exerted heretofore to improve these properties of nonwoven webs, including modification of the manner of manufacturing and/or processing the web. This efforts, however, increase the cost of the nonwoven web and may adversely alter its monetary advantage over woven webs. Further, the fibers of nonwoven webs most commonly are petroleum-based and therefore have been subject to the substantial fluctuations in market price of this raw material, and the important considerations in ultimate disposal of the product after use.

In accordance with the present invention there is provided a novel multilayered composite web; all of the layers of which are nonwoven, and which exhibits the desirable properties of a woven web and the economic advantages of a nonwoven web. The web of the present

invention is multilayered and comprises a first layer of man-made fibrous material selected from the group consisting of thermoplastic meltblown man-made fibers, thermoplastic spunbonded man-made fibers, thermoplastic staple fibers, and combinations thereof, this first layer being light weight and having a weight of between about 0.05 and about 10 oz/yd², and a second layer of cellulose-based staple fibers, excluding wood fibers, and having a weight of between about 0.1 and about 10 oz/yd², the fibers of the second layer having a fiber length of between about 0.5 and about 3.0 inches and a fineness of equivalent to between about 3 and 5 Micronaire units. The layers are preferably thermally bonded together to form a coherent web, the area of bonding between the layers being between about 5 and about 75% of the area of one of the flat surfaces of the composite web. The bonding contemplated in the present invention is of a type which does not adversely affect the hand and other physical characteristics of the web such as liquid wicking and retention rates. Accordingly, the preferred bonding is effected from only one side of the laminate. In a preferred embodiment, the composite web includes at least a third layer of fibrous material selected from the group consisting of thermoplastic meltblown man-made fibers, thermoplastic spunbonded man-made fibers, thermoplastic man-made staple fibers and combinations thereof. This third layer preferably also is light weight and has a weight of between about 0.05 and about 10 oz/yd², and is disposed on that side of the second layer opposite the first layer and thermally bonded to at least the second layer such that the second layer is sandwiched between the first and third layers. Other and additional like layers of like materials may be included in the composite.

The composite web product of the present invention, regardless of the number of layers employed in its makeup, preferably exhibits a final composite weight of between about 0.5 and about 24 oz/yd² in order to approximate a woven web in feel, drapability and other properties.

This limitation upon the present web requires that there be careful selection of the weight of each of the individual layers of the composite web which will provide other desirable or required properties such as strength, wicking, liquid absorption and retention, and barrier properties (ability to exclude liquids while permitting or even encouraging vapor and gas transfer through the thickness of the web).

The composite web of the present invention is particularly useful in the manufacture of disposable medical products because of its superior barrier properties, hand, breathability, strength, wicking and liquid absorption and retention, among other properties.

With reference to the Figures,

Figure 1 is a schematic representation of one embodiment of a web which incorporates various of the features of the present invention;

Figure 2 is a schematic representation of another embodiment of a web which incorporates various of the features of the present invention.

Figure 3 is a schematic representation of a process for the formation of a web which incorporates various of the features of the present invention;

Figure 4 is a schematic representation of a further process for the manufacture of a web which incorporates various of the features of the present invention;

Figure 5 is a schematic representation of a still further process for the manufacture of a web and depicting in-line web-forming apparatus;

Figure 6 is a representation of apparatus for use in liquid absorptivity and retention testing of webs;

Figure 7 is a representation of apparatus for use in testing the wicking property of webs;

Figures 8 through 34 are graphs depicting the wicking values of samples as identified in Table X.

Figure 35 is a graph depicting the wicking response of laminates in accordance with the present

invention and having various cotton core weights;

Figure 36 is a graph depicting the wicking response of nonlaminated cotton webs; and

5 Figure 37 is a graph comparing the wicking response for laminates having a cotton core with a laminate having a ramie core.

With reference to Figure 1, the depicted composite web 10 comprises a first layer 12, and a second layer 14. As depicted, these layers are bonded one to the other
10 as by a pattern of diamond-shaped bonds 16 that are each of substantially the same size and spaced apart from one another. These bond areas preferably extend over substantially the entire area of the composite web and thereby serving to integrate the layers into a coherent web. In
15 Figure 2 there is depicted a further web 10 which includes like first and second layers, 12' and 14' respectively, plus a third layer 20.

At least one of the layers of the composite web of the present invention is of thermoplastic man-made
20 fibers. Accordingly, bonding of the layers of the web one to another may be accomplished by any of several well known thermal bonding means, such as passing the overlaid layers
25 through a set of heated rolls. Preferably, at least one of these rolls is provided with a surface pattern of projections 30 (see Figure 3) which produce spaced apart bonded areas, such as the diamond-shaped areas depicted in Figure 1, by means of the pressure and heat combination provided
30 by the rolls to the composite web as it is fed through the nip between these rolls. Other thermal bonding means such as ultrasonic welding and the like may be employed as desired. Other techniques for joining the layers of the composite web of the present invention may include physical entanglement of the fibers of the several layers as by
35 hydroentanglement, needle punching or the like. In any event, the preferred bonding of the layers one to another is effected by means of spaced apart, and relatively small, bonding areas that extend over substantially the entire

area of the composite web to effectively develop a unitary coherent web from the several layers without detrimental effect upon the desired properties of the web. In a bonding operation, between about 5 and about 75% of the surface area of the composite web comprises bonding areas between the layers of the web. Preferably, however, the total percentage of bond area of the composite web is between about 10 and about 25% of the area of the composite web.

In one embodiment of a method for the manufacture of the composite web of the present invention, preferably each of the layers of the web is formed individually and overlaid in a laminating-type operation. While held in their overlaid condition, the webs are bonded as described hereinabove. It is to be recognized, however, that the several layers of the present web may be formed substantially simultaneously, as in an inline production process, wherein one of the layers is formed and thereupon a second or further layer is formed on the first or previously formed layer. In this latter instance, the bonding operation may also be inline and at a location downstream of the formation of the final layer of the web. These manufacturing techniques are well known to one skilled in the art of web manufacture. In Figure 3, there is depicted schematically a process for overlaying previously formed layers 15, 17 and 19 into a web onto a forwardly moving conveyor 21 and thereafter bonding the layers into a coherent web 10 by passing the web through the nip 24 of a set of heated rolls 26 and 28. In this embodiment, the upper roll 28 is provided with a pattern of surface projections 30 which enhance the formation of the desired spaced apart bond areas 16. As depicted, the composite web 10 is collected in a roll 32 for storage and subsequent use. As desired, each of the webs 15 and 19 is formed from man-made fibers, e.g. by spunbonding, meltblowing or other process which provide a coherent self-sustaining web.

In Figure 4, there is depicted schematically a

process for the manufacture of a web of the present invention in which a first layer 40 of man-made thermoplastic fibers is formed employing a conventional meltblowing or spunbonding process 44 and thereafter deposited on a forwardly moving conveyor 42. A layer 48 of cellulose-based fibers produced either offline or inline as described in Figure 5, is overlaid onto the first layer 40 that is disposed on the moving conveyor 42. A third layer 50 of thermoplastic man-made fibers is formed by a conventional meltblowing or spunbonding process 51 and overlaid onto the cellulose-based layer 48 to provide a three-layered web in which the cellulose-based fibrous layer 48 is disposed between outer layers 40 and 50 of man-made thermoplastic fibrous material. In the depicted process, these several overlaid layers are fed through the nip of a set of heated pressure rolls 54 and 56, one of which has a pattern of projections 58 on its outer surface, to thermally bond the several layers into a coherent web 59. The composite web may be collected in a roll 60 for further use. As will appear more fully hereinafter, one or both of the first and second layers, 40 and 50, may be formed by conventional meltblowing, spunbonding or like techniques, including thermal bonding of man-made staple fiber webs.

With reference to Figure 5, there is depicted a further embodiment of a process for the manufacture of a web in accordance with the present invention. In the depicted process, a first web 64 of man-made fibers is formed as by means of an on-line conventional melt-blowing or spunbonding apparatus 66, fed past an idler roller 65, and deposited on the upper run of a first conveyor 67. As depicted, the process further includes an in-line carding section 68 in which a bale 69 of cellulose-based fibrous material is introduced to an in-line carding unit 70 from which a carded web 71 is fed directly from the carding unit onto a second conveyor 72. From the conveyor 72, the cellulosic web is fed forwardly onto the top of the web 64 on the conveyor 67. Further, a third web 74 of man-made

fibers is formed as by means of a further in-line conventional meltblowing or spunbonding apparatus 75 and fed past an idler roller 76, and overlaid upon the top surface of the cellulosic web 71 wherein the cellulosic layer 71 becomes sandwiched between the webs 64 and 74 of man-made fibers. These layers of webs are fed forwardly through the nip 77 of a set of heated rolls 78 and 79, the upper one 78 of which is provided with projections 81 on its outer cylindrical surface for effecting spaced-apart thermal bonds between at least the top web 74 and the cellulosic web 71 to form the layers into a composite web. The bonded composite 83 is collected in a roll 85 for subsequent storage and use. Optionally, a layer of man-made staple fibers may be formed into a web 87 as by means of a conventional air laying web former 89 and interposed into the composite 83 between the cellulosic web 71 and one or both of the man-made fiber webs 64 and 74.

In the present invention, the composite web comprises at least two layers. In any event, at least one of the layers is formed from cellulose-based fibers. "Cellulose-based" as used herein is intended to include ~~staple fibers which are composed of between about 25% and 100% cellulosic material.~~ Suitable cellulosic materials from which the fibers may be obtained include cotton, ramie, hemp, jute, flax, kenaf, bagasse, eucalyptus, rayon (reconstituted cellulose) and combinations thereof, but does not include wood fibers. ~~The chosen cellulosic fiber typically is processed as is well known in the art to provide a clean, bright fiber which readily absorbs liquids.~~ For example, cotton is scoured and bleached to remove the oils, etc. from the fiber and to render the fibers pliant and absorptive, as well as clean of foreign ~~material and bright in color (white being deemed a color).~~ However, a partial scour with little or no bleaching may provide sufficient absorbency and/or wicking for many applications. The cellulosic fibers which are suitable for use in the web of the present invention are of a length of

between about 0.5 and about 3 inches. Cotton fibers preferably range from about 0.5 to about 1.25 inches in length, whereas ramie or flax fibers may range up to about 3 inches in length. As desired, the longer fibers may be broken or chopped into shorter lengths. The cellulosic fibers employed are not formed into yarns or threads. The fibers, however, may be processed, as by carding or the like, to orient the fibers or preferably to randomize their orientation, and form the fibers into a self-supporting web. As desired, the fibers may be used directly from the bale as received from the fiber processing operation and in this instance will be introduced to the present web as a layer in which the fibers are carded more or less parallel to each other or are randomly oriented. The cotton fibers preferably are of a fineness of between about 3 and 5 Micronaire units so as to be sufficiently flexible to permit the development of the desired hand and drapability, among other properties, of the composite web of the present invention. Cotton fibers of a size larger than about 5 Micronaire units are less flexible and webs formed therefrom tend to be of harsh and unacceptable hand. Cotton fibers are a preferred form of cellulose-based fibers for use in the composite web of the present invention. Cotton fibers have a nonsmooth surface and exhibit a surface energy of about 44 dyne/cm as compared to a surface energy of polyolefins fibers of about 31 dyne/cm, and thereby exhibit a good tendency to remain in place once layered in the composite web of the present invention. Further, cotton fibers contribute to the composite web excellent properties, such as wicking, absorbency and liquid retention, bulk, liquid repellency but vapor and gas permeability, and strength in some of the composite constructions, particularly if meltblown webs lighter than 0.5 oz/yd² (17 g/m²) are used.

Regardless of which of the cellulose-based fibers is employed in the make-up of the inner layer of the present multilayered composite web, the inner layer must be

formed of staple length fibers, as opposed to filament length fibers. The staple fibers, being of relatively short individual lengths, most often being of a mixture of lengths, all of which are less than about 3 inches, and preferably less than about 2 inches, in length, provide a multiplicity of ends of fibers. Inasmuch as these fibers are not formed into yarns, but are present in the inner layer as individual fibers that preferably have no major orientation other than the fact that they are formed into a web that is sufficiently coherent to be handled by automated equipment for overlaying onto a conveyor or a further web on a conveyor, the fiber ends tend to extend in all directions within the web. Many of the fiber ends, therefore, extend generally laterally of the plane of the web and even project from the flat general surface of the web. This characteristic of the staple fiber web is one of the major reasons that it is unacceptable in this form for use in medical applications. In accordance with the present invention, this heretofore unacceptable web is captured between two webs of man-made nonwoven fibers such that the man-made webs serve to contain the short cellulosic fibers. These man-made fibrous webs, however, must be carefully chosen so as to not deleteriously affect the hand and other of the desired properties of the resultant composite web. Also, importantly, the man-made fibrous webs are chosen for their ability to permit the cellulosic fibers of the inner lay to impart to the composite web those desirable properties of hand and liquid wicking and retention. This is accomplished in the present invention by employing webs of man-made fibers which have been formed into webs by processes which develop substantial void volumes in the webs, but which are formed of fibers having a degree of fineness which enables the webs to simultaneously serve the function of a barrier to bacteria, etc. and without adversely inhibiting the transfer of vapor or liquid through the thickness of the web and into the inner layer of cellulosic fibers where the liquid is rapidly

captured and does not strike-through the composite web.

Those ends of the short staple fibers of the inner layer of the composite web which are oriented generally laterally of the plane of the inner layer serve to
5 define many regions of liquid transport into this inner layer. Specifically, the outer layers of the man-made fibers are hydrophobic in nature and have low surface tension values. These fibers also are continuous in length and are poor transporters of liquids. On the other hand,
10 the staple fibers of the inner layer are hydrophilic and have relatively high surface tension values, are nonsmooth, buckled along their length, and present in large numbers so that they tend to draw the liquid into the body of the inner layer. Moreover, the many ends of the staple fibers
15 of the inner layer which extend laterally of the plane of the inner layer define ready pathways for the transport of liquid into the inner layer, both by reason of their affinity to the liquid and the fact that their great numbers, their geometry, and physical orientation in the
20 inner layer define large numbers of capillaries within the inner layer which further enhance the movement of liquids into, and aid in retention of the liquid within, the inner layer. Cotton fibers also swell when wetted so these fibers are preferred in webs where the web is expected to
25 both absorb liquids and serve a barrier function.

As is well recognized in the art, a web of cellulose-based fibers in which the fibers are not bonded
~~one to another is useless in most disposable medical~~
30 ~~products. First, the web is of insufficient strength to be self-sustaining, and second, the fibers tend to free themselves from the web and thereby introduce unacceptable potential sources of contamination. Loose fibers in surgical gowns, for example, which enter an open wound or~~
~~incision can be the source of granulomas within the patient~~
35 and therefore in this application, the fibers must be adequately contained. In accordance with the present invention, the cellulose-based fibers are combined with a

layer of thermoplastic man-made fibers. As will be noted hereinafter, the combination of a layer of cellulose-based fibers with a layer of thermoplastic man-made fibers, when the layers are thermally bonded together at spaced apart locations, provides a coherent composite web that exhibits enhanced properties, especially wicking, liquid retention, and strength. In particular, the layer of man-made fibers provides strength and abrasion resistance to the composite web, and therefore, in a preferred composite web, the layer of cellulose-based fibers is sandwiched between outer layers of man-made fibers.

Whereas the meltblown and spunbonded webs of thermoplastic man-made fibers of the prior art have required special and additional treatment following their formation in order to make these webs useful in disposable medical and sanitary products, the present inventors have found that through the combination of selected ones of these webs with selected cellulose-based layers in a bonded composite web, it is possible to produce a composite web which does not require that the man-made fibrous webs be specially treated, but rather these selected webs can be directly incorporated into the composite web of the present invention. This capability provides the present invention with a substantial economic advantage.

In the present invention, the webs of man-made fibers preferably are formed by meltblowing or spunbonding techniques. Meltblown fibers of these man-made fibers preferably are of a diameter of between about 0.5 and about 10.0 micrometers; whereas, the diameters of the fibers in spunbond webs overlap with meltblown webs on the low end at about 8.0 micrometers and may range up to 50 micrometers or more on the upper end of their diameter range. Spunbond webs generally are coarser but stronger than meltblown webs because spunbond fibers are given notable orientation after quenching. In either instance, the fibers are formed into self-sustaining webs. The preferred web weight of a meltblown web for use in the present invention is light

weight, having a weight in the range of between about 0.05 and about 10 oz/yd², and most preferably between about 0.25 and about 2 oz/yd². The preferred weight of a spunbonded web for use in the present invention is also light weight
5 having a weight between about 0.1 and about 10 oz/yd², and most preferably between about 0.3 and about 2 oz/yd². Webs of weights lighter than about 0.05 oz/yd² tend to be of insufficient fiber density for containing the cellulosic fibers and providing the strength and other properties
10 desired in the composite web. The heavier weight webs, i.e. above about 10 oz/yd² tend to develop undesirably harsh composite webs when combined with the cellulosic fiber layer. More specific descriptions of the spunbonding and meltblowing processes, and the webs so produced are given
15 in the publication entitled: "Proceedings, Fiber Producer Conference 1983", April 12, 13 & 14, 1983, pp. 6-1 through 6-11, such publication being incorporated herein by reference.

As noted, a preferred composite web in accordance
20 with the present invention comprises an inner layer of cellulose-based fibers which is sandwiched between outer layers of man-made fibers. The composite web, therefore, may comprise different combinations of layers. For example, in addition to the required layer of cellulose-based
25 fibers, the composite web may include a first layer of meltblown man-made fibers facing one surface of the cellulose fibers and a third layer comprising spunbonded man-made fibers facing the opposite surface of the cellulose fiber layer. In like manner, the first and third layers
30 may both be either meltblown or spunbonded fibers. Still further, there may be provided multiple layers of cellulose fibers which may or may not be separated by additional inner layers of man-made fibers, either meltblown or spunbonded. In any event, the cellulose fibers are to be
35 protected by at least one outer layer, and preferably two outer layers, of man-made fibers. It will be recognized that the addition of further layers to the composite web

increases the cost of the web and may detract from the hand and other desirable properties of the composite web.

Samples of composite webs employing features of the present invention were manufactured employing the process depicted schematically in Figure 3. In the preparation of the present samples, the cellulose-based fibers were fed to an opener-mixer where the fibers from a bale were opened and uniformly mixed. The fibers from the opener mixer were fed through a card wherein the fibers were carded to develop a web which was doffed directly from the card, without being wound up, and fed onto a layer of thermoplastic man-made fibers carried on a conveyor. The card employed in the manufacture of the present samples had a randomizing unit attached to its exit end so that the fibers were randomly oriented in the web with little or no preferred orientation in the machine direction. Thereafter, a third layer, comprising thermoplastic man-made fibers, was overlaid on top of the cellulose fiber layer so that the cellulose fiber layer was sandwiched between the two outer layers of thermoplastic man-made fibers. This laminate was then fed through the nip between a set of heated rolls, one of which was of a smooth surface and other of which was provided with a patterns of spaced projections, each of which was of a diamond-shaped cross section. Tables I and II provide further details regarding the operational parameters employed in the preparation of these samples and the composition of the various samples.

TABLE I
Parameters and Their Levels

<u>Parameter</u>	<u>No. of Levels</u>	<u>Values</u>
Melt Blown Fabric		
1. Resin Exxon	2	Himont Valtec 442, PD 3495G
2. Fabric Weight	2	0.7 oz/yd ² , 0.5 oz/yd ²
Staple Fiber Web		
1. Weight	1	1.0 oz/yd ²
2. Constituent Fibers lene (PP)	2	Cotton (C), Polypropy-
3. Fiber Denier		
- Cotton Denier	1	1.75 (Veratec 'Easy
Street')		
- PP Denier	2	2.2 (Hercules T-185) 3.0 (BASF bico 'Merge
1080')		
4. Fiber Length		
- Cotton Length	1	1.0 inch
- PP Length	1	1.5 inch
Thermal Bonding Process		
1. Pattern of engraved roll	1	Diamond
2. Area percent of raised pattern	1	16.6%*
3. Nip Pressure inch)	1	250 PLI (pounds/linear
4. Temperature:		
- Top Roll	4	128°C, 133°C, 134°C, 135°C
- Bottom Roll	4	127°C, 129°C, 131°C, 132°C
5. Surface Speed of Calender Rolls	1	29 ft/min

*Bonding area of Kusters Calender used to make samples in Table II

TABLE II
PROCESSING CONDITIONS OF MELT BLOWN/COTTON/MELT BLOWN LAMINATE¹ SAMPLES

Sample No.	Weight of Layers ² (oz/yd ²)	Composition of Layers			Bonding Roll Temperature (°C)		Composition of Composite Web	
		Top	Middle	Bottom	Top	Bottom	Cotton (%)	PP (%)
1	0.7/1.0/0.7	UT-1-24 ³	100% Cotton	UT-1-24	128	129	41.8	58.2
2	0.7/1.0/0.7	UT-1-24	100% Cotton	UT-1-24	134	129	41.8	58.2
3	0.7/1.0/0.5	UT-1-24	100% Cotton	UT-1-17 ⁴	134	129	45.4	54.6
4	0.7/1.0/0.7	UT-1-24	100% PP ⁵	UT-1-24	135	132	0	100
5	0.7/1.0/0.5	UT-1-24	100% PP ⁵	UT-1-17	135	132	0	100
6	0.7/1.0/0.5	UT-1-24	100% BF PP ⁶	UT-1-17	135	132	0	100
7	0.7/1.0/0.7	UT-1-24	100% BF PP ⁶	UT-1-24	135	132	0	100

1 40-inch webs produced.
 2 Outer layers consisted of different weights of meltblown (MB) Polypropylene (PP) and middle layer consisted of staple fiber.
 3 Himont Resin MB Polypropylene (0.7 oz/yd²).
 4 Himont Resin MB Polypropylene (0.5 oz/yd²).
 5 Hercules Grade T-185 Polypropylene.
 6 BASF bicomponent fiber.

The samples produced as listed in Tables I and II were tested for various properties as indicated below:

Barrier. Barrier refers to the ability of a fabric to resist strike-through of fluid and microorganisms. Barrier properties protect the operating room staff and the patient from infection.

	<u>Test</u>	<u>Test Procedure</u>
	<u>Used</u>	
10	Hydrostatic Pressure 127-1985	AATCC Test Method
	Oil Repellency Rating 118-1983	AATCC Test Method
	Water Impact Penetration 42-1985	AATCC Test Method
15	Water Spray Rating 22-1985	AATCC Test Method

Strength. Medical nonwovens also need to be strong enough to prevent tearing and puncturing all the way from manufacturing steps through use of the finished product.

	<u>Test</u>	<u>Test Procedure</u>
	Breaking Load	IST ¹ 110.0 - 70 (82)
	Elmendorf Tear Strength	IST 100.0 - 70 (R82)
25	Mullen Bursting Strength	IST 30.0 - 70 (R82)
	Tensile Elongation	IST 110.0 - 70 (82)

Drapability and Comfort. Drapability of a nonwoven fabric refers to its ability to conform to the shape of the object it is covering. The objects include patients, operating room tables and equipment.

Comfort relates to breathability, selection of materials and product design.

¹INDA (Association of the Nonwovens Fabrics Industry) Standard Test.

<u>Test</u>	<u>Test Procedure</u>
Frazier Air Permeability	IST 70.1 - 70 (R82)
Cantilever Bending Length	ASTM D 1388-64

5

The results of these tests are given in Tables IIIA and IIIB.

TABLE III
TEST RESULTS OF UNFINISHED LAMINATE FABRICS

Sample No.	Bending Length (cms)		Bursting Strength (psi)		Bursting Strength (kPa)		Tear Strength (gms)		Air Permeability		Breaking Strength (kg/cm)		Elongation (%)		Hydrostatic Pressure (cm)		Water Spray Rating		Water Impact Penetration (gm)		Oil Repellency Rating	
	MO	CD	MO	CD	MO	CD	MO	CD	cu. ft/min/ft ²	cu. m/sec/m ²	MO	CD	MO	CD	MO	CD	MO	CD	MO	CD	MO	CD
1	7.22	5.63	11	75.79	98	174	32.00	0.16	0.83	0.54	14	21.2	34	90	0.43	0						
2	7.91	5.97	9.4	64.77	84	126	30.51	0.16	0.90	0.49	11.6	20	32	80	0.37	0						
3	7.02	5.27	7.7	53.05	68	114	32.84	0.17	0.80	0.43	10.4	22.8	24	70	0.9	0						
4	7.4	5.14	19.1	131.60	158	694	30.90	0.16	0.97	0.50	20	24.8	39	70	0.83	0						
5	6.98	5.20	17.3	119.20	126	488	36.70	0.19	0.88	0.40	22.4	21.6	57	80	4.33	0						
6	7.37	5.14	19.4	133.67	166	248	36.42	0.19	1.46	0.45	24.8	24.4	42	80	1.73	0						
7	7.53	5.49	19.1	131.60	112	292	30.17	0.15	1.39	0.54	25	24	48	70	0.33	0						
8	3.68	4.04	39.5	272.16	853	1209	26.37	0.132	1.42	1.59	35.6	34.4	50	90	0	0						
9	3.93	2.70	39.3	270.78	613	660	16.77	0.083	1.49	1.35	22	28.4	62	70	0	8.0						
10	4.62	4.88	40.3	277.67	1179	1755	13.66	0.068	1.32	1.66	31.2	35.2	77	90	0	0						
11	3.90	2.94	42.5	292.83	641	746	11.9	0.059	1.59	1.33	24.8	27.6	58	70	0	7.5						

Note: Sample No. 8 = 1.8 oz/sq.yd unfinished SMS (spunbonded/melt blown/spunbonded) fabric.
 Sample No. 9 = 1.8 oz/sq.yd finished SMS fabric.
 Sample No. 10 = 2.3 oz/sq.yd unfinished SMS fabric.
 Sample No. 11 = 2.3 oz/sq.yd finished SMS fabric.

The data of Table III indicate that the lightweight laminate of the present invention exhibit strength values which are fully suitable for the anticipated use of these laminates as substitutes for the prior art fabrics formed solely from synthetic fibers or filaments, i.e. the prior art SMS fabrics which have heretofore been popular for use in medical applications. The present laminates further exhibit good hand (bending length) and liquid barrier properties, relative to laminates which do not include a layer of cellulosic fibers. As will be seen hereinafter, the laminates of the present invention possess excellent properties relating to liquid absorption, retention and wicking which make the present laminates much more useful and desirable for medical uses, for example.

Repellent Finishing

A fluorochemical finish was given to laminated samples in order to improve their repellency characteristics toward water, oil, blood, alcohol, and other aqueous liquids - and barrier properties of the fabrics.

A padding technique, a conventional method of applying continuous finish was used to give the laminate samples a fluorochemical finish. In this technique, the sample is immersed into the chemical mixture and then passed through the nip of a set of rollers to squeeze out the excess chemicals from the saturated laminate by the application of nip pressure. The nip pressure is adjusted in order to get the desired wet pick up percentage (WPU%). Wet pick up is the amount of finish liquor absorbed by the laminate sample. The unfinished samples were weighed after being cut. The samples passed through the padding mangle for fluorochemical finishing were weighed after finishing treatment. The wet pick up percentage was determined as follows:

$$\text{WPU\%} = \frac{\text{Wt. of Finished Sample} - \text{Wt. of Unfinished Sample}}{\text{Weight of Finished Sample}} \times 100$$

The wet pick up percentage of different laminate samples is given in Table IV.

TABLE IV

WET PICK UP PERCENTAGE OF MSM LAMINATE SAMPLES

	<u>Sample No.</u>	<u>WPU (%)</u>
	1	152.10
5	2	145.50
	3	149.43
	4	157.96
	5	157.90
	6	140.91
10	7	140.11

Fluorochemical finishing was carried out using a 18" wide padding mangle. The fluorochemical used to treat the laminate samples was 5% "Zonyl" PPR Fabric Protector from Dupont. A wet pick up of 140% was planned for. The samples were given a fluorochemical finish in the padding mangle with two dips and two nips at a pressure of 30 psi. The finished samples were then cured in a convection oven at 250°F for 3.5 minutes on a pin frame. The following fluorochemical formulation was used:

Padding Application (Planned wet pick up of 140%)

	<u>Ingredients</u>	<u>% by weight</u>
	Zonyl PPR	3.6
	Water	<u>96.4</u>
15	Total	<u>100.0</u>

The fluorochemically finished samples were tested for barrier, strength, and drapability and comfort properties using the test procedures as given earlier. The results for finished laminate samples are shown in Tables V.

TABLE V
TEST RESULTS OF REPELLENT FINISHED LAMINATE FABRICS

Sample No.	Sewing Length (cm)		Bursting Strength (psi)	Bursting Strength (KPa)	Tear Strength (gm)		Air Permeability		Stretching Strength (Kg/cm)	Elongation (%)		Hydrostatic Pressure (cm)	Water Spray Rating	Water Impact Penetration (gm)	Oil Repellency Rating	
	MD	CD			MD	CD	cu.ft./min/ft ²	cu.m/sec/m ²		MD	CD					MD
1	6.92	5.60	10.8	74.41	76	108	28.28	0.14	0.80	0.48	16	22	45	90	0.23	8
2	6.67	5.34	10.65	73.38	66	104	27.93	0.14	0.76	0.46	14	14	44	90	0.27	8
3	6.87	5.65	10.45	72.00	62	100	32.24	0.16	0.59	0.39	14	26	40	80	0.33	8
4	6.48	5.06	17.05	117.47	146	664	29.91	0.15	0.91	0.46	38	22	39	80	0.13	7
5	5.98	5.67	16.2	111.62	122	388	29.14	0.15	0.95	0.41	16	20	32	90	0.27	8
6	6.59	5.41	18.7	128.84	136	354	29.65	0.15	1.35	0.46	30	26	35	80	0.17	6
7	6.45	5.24	18.85	129.88	114	404	28.19	0.14	1.41	0.51	30	32	40	70	0.13	6

The hydrostatic pressure levels needed to pass liquid through the samples were already notably high with the unfinished samples which attest to the good barrier properties provided by the meltblown webs. However, the repellent finished samples 1, 2 and 3 which contained only cotton staple fiber in the center layer had much higher hydrostatic pressure levels than the corresponding unfinished samples, and had generally greater hydrostatic pressure values than the finished samples with only polypropylene (PP) in the center. On the other hand, the hydrostatic pressures of most of the samples with only PP in the core were notably decreased by repellent finishes. The water spray rating of the majority of the finished samples were seen to have increased as a result of fluorochemical finishing. The greatest advantage in applying a fluorochemical finish was seen in the increase of oil repellency rating from a very poor 0.0 (in unfinished samples) to an excellent range of 6.0 - 8.0 (in fluorochemically finished samples). Again, the fluorochemically finished samples containing only cotton in the core consistently had the highest oil repellency values of 8.

A further series of samples, numbered 8-15 in the following tables, were prepared for comparison purposes. Except for the Sontara fabrics which contained wood pulp, none of these samples included a cellulose-based fibrous layer, but rather comprised one or more layers of man-made fibers. Table VI gives the composition and method of manufacture of each of these samples.

TABLE VI

NONWOVEN FABRIC CONSTRUCTION
AND TYPE OF FINISH

	No.	Fabric Type	Fiber Content	Construction	Finish
5	8	Tyvek 1422A	100% PE ¹	Spunbonded	None
	9	Tyvek 1422R	100% PE	Spunbonded	Corona Treated
10	10	Sontara	50% Polyester	Spunlaced	None
	11	Sontara	50% Polyester	Composite	DuPont RF ⁴
15	12	SMS (1.8 oz/yd ²)	50% Wood Pulp	Spunlaced	None
	13	SMS (1.8 oz/yd ²)	100% PP ²	Lam-SMS ³	KC RF ⁵
	14	SMS (2.3 oz/yd ²)	100% PP	Lam-SMS	None
	15	SMS (2.3 oz/yd ²)	100% PP	Lam-SMS	KC RF

¹PE - Polyethylene

²PP - Polypropylene

20 ³Lam-SMS - Thermally point bonded laminate of spunbonded/melt blown/spunbonded nonwoven fabric

⁴DuPont RF - Repellent furnished by DuPont.

⁵KC RF - Repellent furnished by Kimberly-Clark.

These samples were tested for various of the properties which are considered important in laminates employed as substitutes for woven webs. The results of these tests are given in Table VII.

TABLE VII

WEIGHT, THICKNESS, BENDING LENGTH, AIR PERMEABILITY, WATER SPRAY RATING, IMPACT PENETRATION AND OIL REPELLENCY OF REGULAR AND CORONA TREATED "TYVEK" AND OF UNFINISHED AND REPELLENT FINISHED "SOMTARA" AND "SMS" FABRICS¹

	"Tyvek"		"Somtara"		"SMS"		
	1422A Regular Unfinished	1422B Corona Treated Unfinished	Unfinished	Repellent Finished	Nominal 1.8 oz/yd ² Unfinished	Nominal 2.3 oz/yd ² Unfinished	Repellent Finished
Weight Average (oz/yd²)	1.30	1.23	2.11	2.14	1.78	2.32	2.38
Thickness Average (mils)	6.60	5.90	11.20	12.60	14.50	17.00	14.60
Bending Length Average							
Face Side (cm)	3.92	4.13	5.28	3.46	3.67	4.54	4.90
Back Side (cm)	4.16	5.10	7.16	4.74	4.34	3.59	4.38
Air Permeability Average (ft³/min/ft²)	0	0	52.6	58.7	17.6	10.9	5.1
Water Spray Rating (0-100)	90	76	0	90	90	90	70
First Set	90	80	0	90	90	90	70
Second Set	0	0	23.7	0.2	0	0	0
Water Impact² Penetration (g)	2	0	0	8	0	0	7.4
First Set	2	0	0	8	0	0	7.6
Second Set							
Bursting Strength (psi)					39.5	40.3	42.5
Hydrostatic Pressure (cm)					50.0	77.0	58.0
Tear Strength (gms)					MO CD 853 1209	MO CD 1179 1755	MO CD 641 746
Breaking Strength (kg/cm)					1.42 1.59	1.49 1.35	1.32 1.66
Elongation (%)					35.6 34.4	22.0 28.4	31.2 35.2
							24.8 27.6

¹ Each value represents the average of 35 specimens.
² Due to the large specimen size required for this test, only one set of five specimens were tested for each sample.

For further comparison several different woven fabrics varying in fiber content, weight and finish and as described in Table VIII were obtained from a commercial source. The 100% cotton denim fabrics would be used as trouser materials. The poplin fabrics would be used for both pants and shirts. The denim fabrics were available in nominal weights of 10, 12 and 14.5 oz/yd². The "indigo" denims consisted of greige fabrics (not desized), desized and light scoured fabrics, and desized, lightly scoured and fluorochemical finished fabrics. The "white" denim fabrics and the poplin fabrics were desized, scoured and bleached. A portion of the "white" denim fabrics were also fluorochemical finished. The poplin fabrics were evaluated after the stages of desizing, scouring and bleaching, durable process finishing and after the combination of durable press and fluorochemical finishing. All the preparatory finishing, and durable press and repellent finishing processes were performed using commercial equipment at a commercial facility. Data further identifying these fabrics are given in Table VIII. The results of tests performed on the fabrics are given in Table IX.

TABLE VIII

YARN COUNT, THREAD COUNT AND TYPE OF CONSTRUCTION OF DENIM AND POPLIN FABRICS

Fabric	Description	Nominal Yarn weight (oz/yd ²)	Warp	Fill	Ends/Inch	Count picks/Inch	Fabric Construction
<u>100% Cotton Denims</u>							
13-A-B1 ¹	Not Desized	10.0	6.20	9.49	65	48	2 x 1 Twill
13-B-B1		12.0	5.77	7.39	72	45	3 x 1 Twill
13-C-B1		14.5	4.52	5.58	61	43	3 x 1 Twill
14-A-W ²	Desized & Scoured	10.0	8.80	7.35	76	44	3 x 1 Twill
124-A-B1 ³		10.0	8.13	10.56	65	42	2 x 1 Twill
14-B-B1		12.0	8.02	7.84	73	41	3 x 1 Twill
14-C-W		14.5	6.74	5.75	68	42	3 x 1 Twill
14-C-B1		14.5	5.28	5.59	61	40	3 x 1 Twill
15-A-W	Desized, Scoured &	10.0	9.21	6.92	75	43	3 x 1 Twill
15-A-B1		12.0	7.79	8.85	73	41	3 x 1 Twill
15-C-W		14.5	6.57	5.25	66	41	3 x 1 Twill
15-C-B1		14.5	6.29	5.84	62	39	3 x 1 Twill
<u>100% Cotton Poplins</u>							
16-W	D+S+B ⁴	16.10	13.89		64	56	Plain
17-W	D+S+B+DP ⁵	15.60	13.08		66	56	Plain
18-W	D+S+B+DP+FC ⁶	15.15	11.54		66	54	Plain
<u>75/25 Cotton/Polyester Poplins</u>							
19-W	D+S+B				66	56	Plain
20-W	D+S+B+DP				67	55	Plain
21-W	D+S+B+DP+FC				66	56	Plain

¹Bl indicates Indigo Denim Fabrics.
²w indicates White Denim Fabrics. The White Denim Fabrics were Desized, Scoured and Bleached.
³Indigo Denim Fabrics were given a Light Desizing and Scouring treatment.
⁴Desized, Scoured and Bleached.
⁵Desized, Scoured, Bleached and Durable Press Finished.
⁶Desized, Scoured, Bleached, Durable Press and Fluorocarbon Finished.

TABLE IX
FABRIC WEIGHT, THICKNESS AND AIR PERMEABILITY VALUES
OF DENIM AND POPLIN FABRICS¹

Fabric Number	Description	Nominal Weight (oz/yd ²)	Actual Weight (oz/yd ²)	Weight (g/m ²)	Thickness (mils)	Air Permeability (ft ³ /min/ft ²)	Air Permeability (m ³ /sec/m ²)
<u>100% Cotton Denims</u>							
13-A-B1 ³	Not Desized	10.0	10.55	357.74	31.53	16.65	0.02
13-B-B1		12.0	12.67	429.72	35.90	23.52	0.115
13-C-B1		14.5	14.92	505.81	39.36	16.11	0.082
14-A-W ⁴	Desized & Scoured	10.0	9.77	311.33	25.74	7.06	0.036
14-A-B1 ⁵		10.0	8.24	279.45	21.96	13.81	0.070
14-B-B1		12.0	9.63	326.35	26.85	13.47	0.068
14-C-W		14.5	11.38	385.92	28.89	7.73	0.039
14-C-B1		14.5	11.54	391.24	30.20	9.59	0.049
15-A-W	Desized	10.0	9.88	334.86	25.43	6.57	0.038
15-A-B1	Scoured & FC Finished	10.0	8.23	278.88	32.01	13.86	0.070
15-B-B1		12.0	9.67	327.97	26.31	11.73	0.060
15-C-W		14.5	11.47	388.90	28.30	8.18	0.042
15-C-B1		14.5	11.67	395.68	30.08	8.98	0.046
<u>100% Cotton Poplins</u>							
16-W	D+S+B ⁶		5.53	187.47	15.63	37.15	0.189
17-W	D+S+B+DP ⁷		5.74	194.65	15.68	37.91	0.193
18-W	D+S+B+DP+FC ⁸		5.82	197.37	15.67	39.13	0.199
<u>75/25 Cotton/Polyester Poplins</u>							
19-W	D+S+B		5.52	186.99	16.14	27.54	0.14
20-W	D+S+B+DP		5.78	196.08	15.87	26.58	0.13
21-W	D+S+B+DP+FC		5.85	198.45	15.78	26.53	0.13

¹The value for each fabric represents the average of 50 specimens measured twice.
²The value for each fabric represents the average of 50 specimens
³B1 indicates Indigo Denim Fabrics.
⁴W indicates White Denim Fabrics. The White Denim Fabrics were Desized, Scoured and Bleached.
⁵Indigo Denim Fabrics were given a Light Desizing and Scouring Treatment.
⁶Desized, Scoured and Bleached.
⁷Desized, Scoured, Bleached and Durable Press Finished.
⁸Desized, Scoured, Bleached, durable Press and Fluorocarbon Finished.

The composite webs of the present invention exhibited hand and drapability approximating that of woven webs of the type heretofore used in surgical gowns and similar medical applications. The air permeability of the present composite webs, i.e, between about 25 and about 37 ft³/min/ft², also is comparable to that of woven webs such as shirting material and therefore provides barrier properties and breathability equivalent to such woven webs. The presence of the fibrous layer in the present composite web provides enhancement of the filtration efficiency of the present web over the single-layered woven webs of the prior art, thereby enhancing the usefulness of the present composite web in applications where the barrier properties of the web are of importance.

The absorbent capacity and retention capacity of several prior art fabrics, cotton mats and laminates made in accordance with the present invention were examined. The absorbent capacity was determined by using an adaptation of the procedure developed at the Swedish Institute for Textile Research (TEFO) and reported by Shishoo (TAPPI Journal, July 1987). Figure 6 depicts the testing apparatus which consists of a large funnel 80 with a glass frit 82 and a graduated collection cylinder 84. A circular specimen 86 with an area of 100 cm² was conditioned overnight at 21°C and 65% RH. The sample was placed face upwards on the glass frit. One hundred milliliters of liquid delivered at a rate of 7 mm/sec from a height of 2.54 cm was used to saturate the specimen. A 100 cm² circular weight 88 of 100 gm was promptly placed on the saturated specimen and the assembly allowed to drain for 10 minutes. The amount of liquid collected in the cylinder was determined and used to calculate the absorbent capacity (C) of the product by the following calculation.

C = a-b where a = total liquid dosage (100 ml)
and b = liquid unabsorbed (ml) under
100Pa pressure.

Seven replications were completed for each sheet examined and the results are reported to the nearest milliliter. The retention capacity was determined as a continuation of the absorbent capacity determination. After determining
 5 the amount of unabsorbed liquid at the end of 10 minutes in the capacity test, 2.9 kg of weight was loaded on top of the sample for a total pressure of 3kPa (100 Pa were already on the specimen from the capacity test) and the assembly allowed to drain for five minutes. The amount of
 10 liquid in the cylinder at the end of this elapsed time was noted and an additional 2 kg of weight were added for a final total of 5kPa. The wetted sample was allowed to stand for five more minutes and the amount of liquid collected in the cylinder was then determined. The amount
 15 of liquid (C_{rm} and C'_{rm}) retained in the sample under the two different pressures was determined by;

$$C_{rm} = C - c \quad \text{where } C = \text{absorption capacity}$$

c = liquid unabsorbed under 3kPa pressure and

$$20 \quad C'_{rm} = C - c' \quad \text{where } C = \text{absorption capacity}$$

c' = liquid unabsorbed under 5kPa pressure

Seven replications of this test were completed for each sheet and the results expressed to the nearest milliliter.
 25 The results of these tests are given in Table XI. For further comparison, the absorbent capacity and retention capacity of 100% carded cotton webs under various weight loadings are also shown in Table XII. Sample Nos. 37-40 of Table XI do not contain a cellulosic fiber layer. Notably
 30 their absorbent and retention capacities are negligible. From these data and the data of earlier tables, it is readily apparent that the laminates of the present invention are superior in many physical respects over the man-made nonwoven fabrics of the prior art, especially for
 35 medical and like applications. The present fabrics also are lightweight and, in fact, those fabrics having lesser amounts (by weight) of meltblown material were noted to be

superior with respect to liquid absorbent and retention capacities, thereby affording an economic advantage also. Further, even though 100% cotton webs were noted to lose some of their retention capacity as the weight of the web increased, when these same cotton webs were incorporated into the laminated structure of the present invention, the resultant laminate unexpectedly exhibited improved retention capacity with increasing weight of cotton in the inner layer.

Table X
Laminated Fabrics Bonded on Küsters Calender¹

Sample No.	Sample Designation (Top Layer)	Polymer Composition of MB Webs (Top Layer)	Sample Designation (Bottom Layer)	Polymer Composition of Webs (Bottom Layer)	Weight of Core Web (oz/yd ²)
20	OC-13-88-5	1.5 oz/yd ² EVA	OC-13-88-5	1.5 oz/yd ² EVA	1.0 Cotton ²
21	JA-12-88	1.0 oz/yd ² EMA	JA-12-88	1.0 oz/yd ² EMA	1.0 Cotton ²
22 ³	May 1-90-3	1.0 oz/yd ² Nylon 6	May 1-90-3	1.0 oz/yd ² Nylon 6	1.0 Cotton ²
23 ³	OC-25-90-2	1.0 oz/yd ² Eastman PET 12270	OC-25-90-2	1.0 oz/yd ² Eastman PET 12270	1.0 Cotton ²
24 ³	AU-20-91-8	1.0 oz/yd ² Celanese FBI 1300A	AU-20-91-8	1.0 oz/yd ² Celanese PBT 1300A	1.0 Cotton ²
25A, 25B	NO-15-90-1B	1.0 oz/yd ² PE	NO-15-90-1B	1.0 oz/yd ² PE	1.0 Cotton ²
26A, 26B, 26C	OC-11-89-3	0.25 oz/yd ² PP	OC-11-89-3	0.25 oz/yd ² PP	1.0 Cotton ²
27 ³	OC-12-89-5	1.0 oz/yd ² Blue PP	OC-12-89-5	1.0 oz/yd ² Blue PP	1.0 Cotton ²
28A, 28B, 28C ³	UT-1-24	0.7 oz/yd ² PP	UT-1-24	0.7 oz/yd ² PP	2.0 Cotton ²

Table X₁ (con'd)

Sample NO.	Sample Designation (Top Layer)	Polymer Composition of MB Webs (Top Layer)	Sample Designation (Bottom Layer)	Polymer Composition of Webs (Bottom Layer)	Weight of Core Web (oz/yd ²)
29A, 29B, 29C	UT-1-24	0.7 oz/yd ² PP	UT-1-24	0.7 oz/yd ² PP	3.0 Cotton ²
30A, 30B, 30C	UT-1-24	0.7 oz./yd ² PP	UT-1-24	0.7 oz/yd ² PP	4.0 Cotton ²
31A, 31B, 31C, 31D	UT-1-24	0.7 oz/yd ² PP	UT-1-24	0.7 oz/yd ² PP	1.0 Cotton ²
32A, 32B, 32C, 32D	UT-1-24	0.7 oz/yd ² PP	UT-1-24	0.7 oz/yd ² PP	1.0 Ramie
33	UT-1-24	0.7 oz/yd ² PP	100% PP SB	0.6 oz/yd ² PP	3.0 Cotton ²
34	UT-1-24	0.7 oz/yd ² PP	100% PP SB	0.6 oz/yd ² PP	1.0 Ramie
35	UT-1-24	0.7 oz/yd ² PP	100% PP SB	0.6 oz/yd ² PP	2.0 Ramie
36	UT-1-24	0.7 oz/yd ² PP	100% PP SB	0.6 oz/yd ² PP	3.0 Ramie
37	UT-1-24	0.7 oz/yd ² PP	UT-1-24	0.7 oz/yd ² PP	-
38	UT-1-24	0.7 oz/yd ² PP	UT-1-17	0.5 oz/yd ² PP	-
39	OC-11-89-3	0.25 oz/yd ² PP	OC-11-89-3	0.25 oz/yd ² PP	-
40	UT-1-24	0.7 oz/yd ² PP	100% PP SB	0.6 oz/yd ² PP	-

Table XI (con'd)

Sample No.	Sample Designation (Top Layer)	Polymer Composition of MB Webs (Top Layer)	Sample Designation (Bottom Layer)	Polymer Composition of Webs (Bottom Layer)	Weight of Core Web (oz/yd ²)
41	100% PP SB	0.9 oz./yd ² PP	100% PP SB	0.9 oz/yd ² PP	2.0 Cotton ²
42	100% PP SB	0.9 oz./yd ² PP	100% PP SB	0.9 oz/yd ² PP	1.0 Cotton ²
43	100% PP SB	0.6 oz./yd ² PP	100% PP SB	0.6 oz/yd ² PP	2.0 Cotton ²
44	100% PP SB	0.6 oz/yd ² PP	100% PP SB	0.6 oz/yd ² PP	1.0 Cotton ²
45	Thermal Bonded	0.6oz/yd ² TBS ² PP	Thermal Bonded	0.6 oz/yd ² TBS ³ PP	1.0 Cotton ²
46	100% PP SB	0.6 oz/yd ² PP	Thermal Bonded	0.6 oz/yd ² TBS ³ PP	1.0 Cotton ²
47	Thermal Bonded	0.6 oz/yd ² TBS ³ PP	UT-1-24 (MB)	0.7 oz/yd ² PP	4.0 Cotton ²

¹Laminated and thermally bonded with a Kusters Calender with a diamond pattern with 14.7% bonding area. Samples 20 and 21 were bonded at 150 PLI pressure with 41°C on the top patterned roll and 41°C on the bottom smooth roll at a fabric speed of 10 yd/min (9.1 m/min). Samples 25A and 25B were bonded using a top roll temperature of 88°C and bottom roll temperature of 90°C with 250 PLI and a fabric speed of 10 yd/min (9.1 m/min). Samples 26A and 26B were bonded using a top roll temperature of 105°C and bottom roll temperature of 100°C with 250 PLI and a fabric speed of 10 yd/min (9.1 m/min). Samples 22, 23, 24, 27, 28A, 28B, 28C, 29A, 29B, 29C, 30A, 30B, 30C, 31A, 31B, 32A and 32B were bonded using a top roll temperature of 134°C and bottom roll temperature of 129°C with 250 PLI and a fabric speed of 10 yd/min (9.1 m/min). The remainder of these samples, not otherwise designated, were laminated under the same conditions except the temperature of the top and bottom rolls were 125°C and 122°C respectively.

Veratec "Easy Street" desized, scoured, and bleached cotton carded on 40 - inch Hollingsworth - On - wheels card and with a combination of flats and half granular clothing. The webs were rolled up on a cylinder 18 cms wide and 1.5 meters in circumference.

Not calendered

Thermally bonded staple fiber nonwoven obtained from Veratec.

NOTE: (a) Samples 31C and 31D; and 32C and 32D were bonded with a Ramisch Kleinswebers calender with 21.6% bonding area at 250 PLI pressure with 134°C on the top roll and 129°C on the bottom roll and a fabric speed of 10 yd/min (9.1 m/min).

(b) Samples 26D, 26E, and 26F; 28D, 28E, and 28F; 29D, 29E, and 29F; 30D, 30E, and 30F were bonded with a Ramisch Kleinswebers calender with 21.6% bonding area at 250 PLI pressure with 134°C on the top roll and 129°C on the bottom roll and a fabric speed of 10 yd/min (9.1 m/min).

TABLE XI
ABSORBENT CAPACITY AND RETENTION CAPACITY

<u>Sample No.</u>	<u>Absorption Capacity (100 Pa)</u>	<u>Retention Capacity (3 kPa)</u>	<u>Retention Capacity (5 kPa)</u>
Tyvek 1422A	5	5	5
Tyvek 1422R	6	5.5	5
Sontara (unfinished)	8	7	7
SMS (unfinished) (1.8 OSY)	8	8	8
SMS (unfinished) (2.3 OSY) 20*	5 12	5 10	5 9.5
21*	9.5	9.0	8.5
22*	14	12	12
25A, 25B*	7.0	6.0	6.0
26A, 26B*	8.5	8.0	8.0

Table XI (con'd)

Sample No.	Absorption Capacity (100 Pa)	Retention Capacity (3 kPa)	Retention Capacity (5 kPa)
27*	8.5	8.0	8.0
28*	11	9.5	9.0
29*	14.5	12	11.5
30*	17	14.5	14
31A, 31B*	8	7.0	6.5
32A, 32B*	7.5	6.5	6.0
33*	18	15	14
34*	7	6.5	6.0
35*	12	11	11
36*	17	14	13
37*	4	4.0	4.0
38*	7	7.0	7.0
39*	8	7.5	7.5
40*	7	7.0	7.0

* See Tables VI and X for description of samples (Sample Nos. correspond with those in Tables VI and X)

Table XI (con'd)

Sample No.	Absorption Capacity (100 Pa)	Retention Capacity (3 kPa) ¹	Retention Capacity (5 kPa) ³
41	16	14	13.5
42	9.0	7.5	7.0
43	14	11	10.5
44	10	9.0	8.0
45	12	11	11.0
46	8.5	7.0	7.0
47	28	18	17

¹ Determined by subtracting the amount of liquid drained into the graduated cylinder at the end of 10 minutes from the original 100 ml dosage.

² Determined by subtracting the amount of liquid unabsorbed at 3 kpa pressure from the absorption capacity.

³ Determined by subtracting the amount of liquid unabsorbed at 5 kpa pressure from the absorption capacity.

TABLE XII

Sample No.	Absorption Capacity (100 Pa)	Retention Capacity (3 kPa) ¹	Retention Capacity (5 kPa) ³
1.0 oz/sq.yd.	24	20.5	19.5
2.0 oz/sq.yd.	33	20.0	19.0
3.0 oz/sq.yd.	34	18.5	16.5
4.0 oz/sq.yd.	46	23	21.0

¹ Determined by subtracting the amount of liquid drained into the graduated cylinder at the end of 10 minutes from the original 100 ml dosage.

² Determined by subtracting the amount of liquid unabsorbed at 3 kPa pressure from the absorption capacity.

³ Determined by subtracting the amount of liquid unabsorbed at 5 kPa pressure from the absorption capacity.

Wicking of the samples was tested employing equipment setup as shown in Figure 7. This equipment included a toploading balance 90 with attached printer 92; laboratory jack 94; water reservoir 95 to hold test liquid 96; funnel 98 with coarse (40-60 micron) glass frit 100; rubber tubing 102 to connect funnel 98 to water reservoir 94; 100g circular weight 106 (area, 100 cm²); and a stopwatch (not shown). The funnel 98 is vertically adjustably mounted on a ring stand 110. One hundred cm² circular samples 108 are cut randomly from a sheet that had been conditioned at 20°C and 65% relative humidity overnight. Seven samples are cut from each sheet to be tested. Procedurally, the test liquid reservoir was raised until the surface of the glass frit was moist (but water was not standing on it). The specimen was placed on the frit with the 100g circular weight on top. A stopwatch was started with the placement of the weight on the sample and a reading of the weight of test liquid lost from the reservoir to the sample was taken every 10 seconds over an interval of 3 minutes. This provided sufficient time to allow the amount of liquid wicked into the sample to stabilize. The result was plotted on a time versus amount curve. This procedure was replicated seven times for each sheet evaluated. Identification of the several samples is given in Table X. The time vs. amount curves which resulted from the testing of these samples are presented in Figures 8 through 34.

Most notably, observation of Figs. 8-34 reveals that the wicking characteristic of the prior art laminates comprising man-made fibers or filaments display very poor wicking. On the other hand, when these same fabrics are laminated with a layer of natural cellulosic fibers, the resultant fabric exhibits excellent wicking properties, thereby providing the desired fabric for medical and other applications.

Whereas the invention has been described by way

of specific examples, it is intended that the invention include various modifications as will be recognized by one skilled in the art. For example, various bonding patterns, other than the diamond pattern which is described may be employed. Further, various fluorochemical finishes are commercially available and well known in the industry, e.g., see the Handbook of Fiber Science and Technology: Volume II. Chemical Processing of Fibers and Fabrics, Functional Finishes, Part B, edited by Menachem Lewin and Stephen B. Sello, incorporated herein by reference, and particularly pp. 172-183.

CLAIMS:

1. A multilayered nonwoven composite web particularly useful as a substitute for a woven web comprising a first layer of fibrous material selected from the group consisting of thermoplastic meltblown man-made fibers, thermoplastic spunbonded man-made fibers, thermoplastic man-made staple fibers and combinations thereof, said first layer having a weight of between about 0.05 and about 10 oz/yd², and most preferably between about 0.25 and about 2.0 oz/yd², and a second layer of cellulose-based staple fibers, said second layer having a weight of between about 0.1 to about 10 oz/yd², and most preferably between about 1 and about 4 oz/yd², the fibers of said second layer having a fiber length of between about 0.5 and about 3 inches and a fiber weight equivalent to between about 2 and about 5 Micronaire units, said first and second layers being thermally bonded together to form a coherent web having an air permeability of between about 25 and about 37 ft³/min/ft², the area of bonding between the layers being between about 5 and about 75% of one of the area of the composite web, and preferably between about 10% and about 30% of the area of the composite web.

2. The composite web of Claim 1 and including a third layer of fibrous material selected from the group consisting of thermoplastic meltblown man-made fibers, thermoplastic spunbonded man-made fibers, thermoplastic man-made staple fibers and combinations thereof, said third layer having a weight of between about 0.05 and about 10

oz/yd², and most preferably between about 0.10 and about 2.0
oz/yd², said third layer being disposed on that side of said
second layer opposite of said first layer and thermally
10 bonded to at least said second layer such that said second
layer is sandwiched between said first and third layers.

3. The composite web of Claims 1 or 2 wherein
said layers are bonded together at spaced locations over
the flat area of said web in a pattern of substantially
equally spaced apart areas.

4. The composite web of Claims 1 or 2 wherein
each of said first and third layers exhibits a void volume
in excess of about 85%

5. The composite web of Claims 1 or 2 wherein
said composite web exhibits a wicking rate of water of
between about 0.01 g/sec. and about 0.05 g/sec., a water
retention value at 3kPa of between about 7 and about 15.

5 6. The composite web of Claims 1 or 2 wherein
said composite web has a bursting strength of between about
40 and about 225 kPa.

AMENDED CLAIMS

[received by the International Bureau on 28 June 1993 (28.06.93); original claim 2 cancelled; original claims 1,3-6 amended (2 pages)]

Claim 1. A multilayered nonwoven composite web particularly useful as a substrate for a woven web comprising a first layer of fibrous material selected from the group consisting of man-made fibers, thermoplastic man-made staple fibers and combinations thereof, said first layer having a weight of between about 0.05 and about 10 oz/yd², and most preferably between about 0.25 and about 2.0 oz/yd², and a second layer of non-wood cellulose-based staple fibers, said second layer having a weight of between about 0.1 to about 10 oz/yd², and most preferably between about 1 and about 4 oz/yd², the fibers of said layer having a fiber length of between about 0.5 and about 3 inches and a fiber weight equivalent to between about 2 and about 5 Micronaire units, and a third layer of fibrous material selected from the group consisting of thermoplastic man-made fibers, thermoplastic man-made staple fibers, and combinations thereof, said third layer having a weight of between about 0.05 and about 10 oz/yd², said third layer being disposed on that side of said second layer opposite of said first layer, said first, second and third layers being disposed in overlying orientation and thermally bonded such that said second layer is sandwiched between said first and third layers with portions of said second layer projecting into or through at least one of said second and third layers, said first and second layers being thermally bonded together to form a coherent web having an air permeability of between about 25 and about 37 ft³/min/ft², the area of bonding between the layers being between about 5 and about 75% of one of the area of the composite web, and preferably between about 10% and about 30% of the area of the composite web.

Claim 2. Canceled.

Claim 3. The composite web of Claim 1 wherein said layers are thermally bonded together at spaced locations over the flat area of said web in a pattern of substantially equally spaced apart thermally bonded areas.

Claim 4. The composite web of Claim 1 wherein each of said first and third layers exhibits a void volume in excess of 85%.

Claim 5. The composite web of Claim 1 wherein said composite web exhibits a wicking rate of water of between about 0.01 g/sec. and about 0.05 g/sec., and a water retention value of 3kPa of between about 7 and about 15.

Claim 6. The composite web of Claim 1 wherein said composite web has a bursting strength of between about 40 and about 225 kPa.

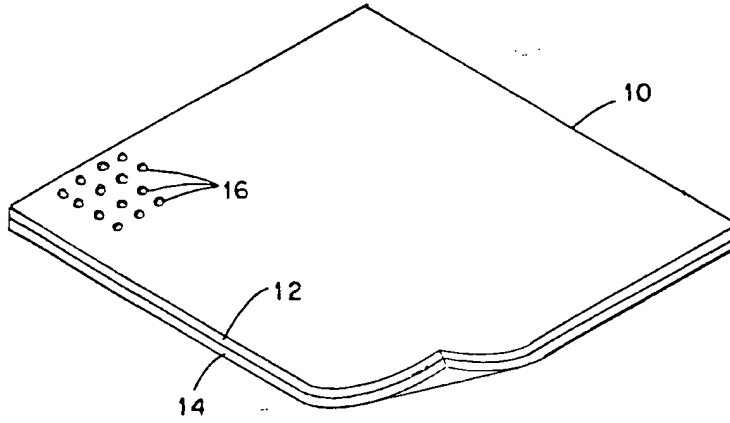

Fig. 1

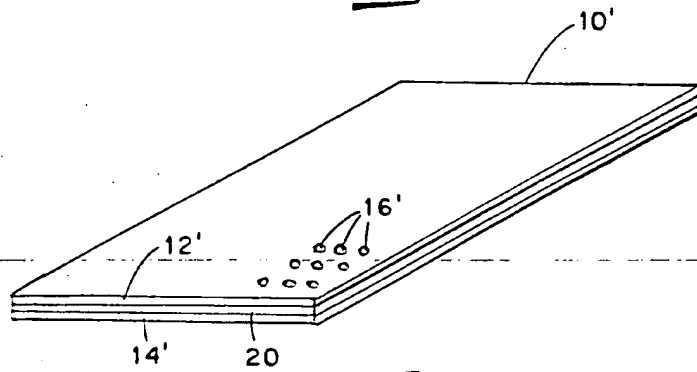

Fig. 2

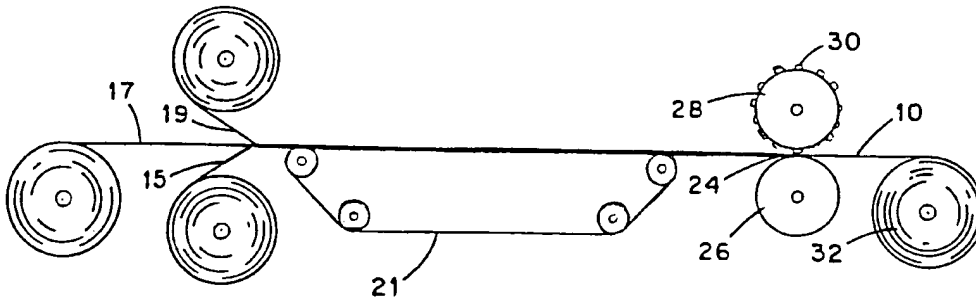
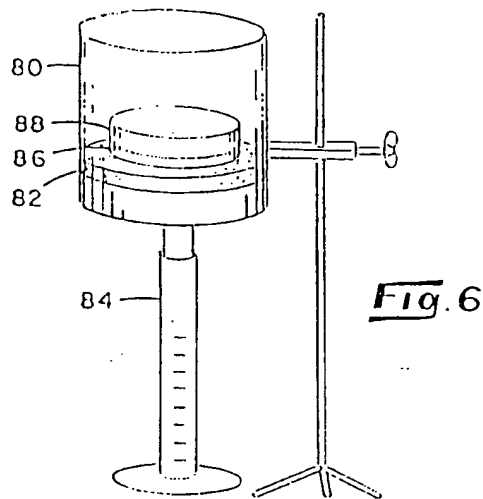
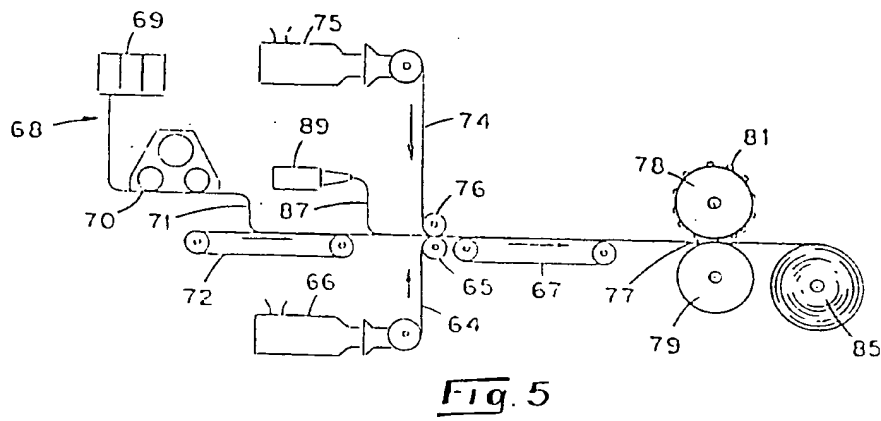
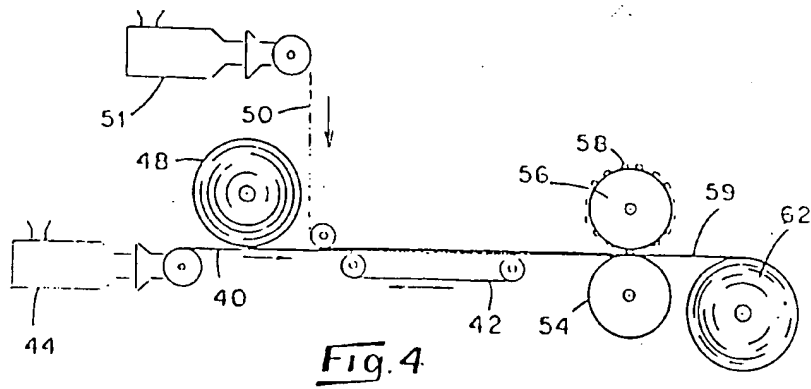

Fig. 3

SUBSTITUTE SHEET



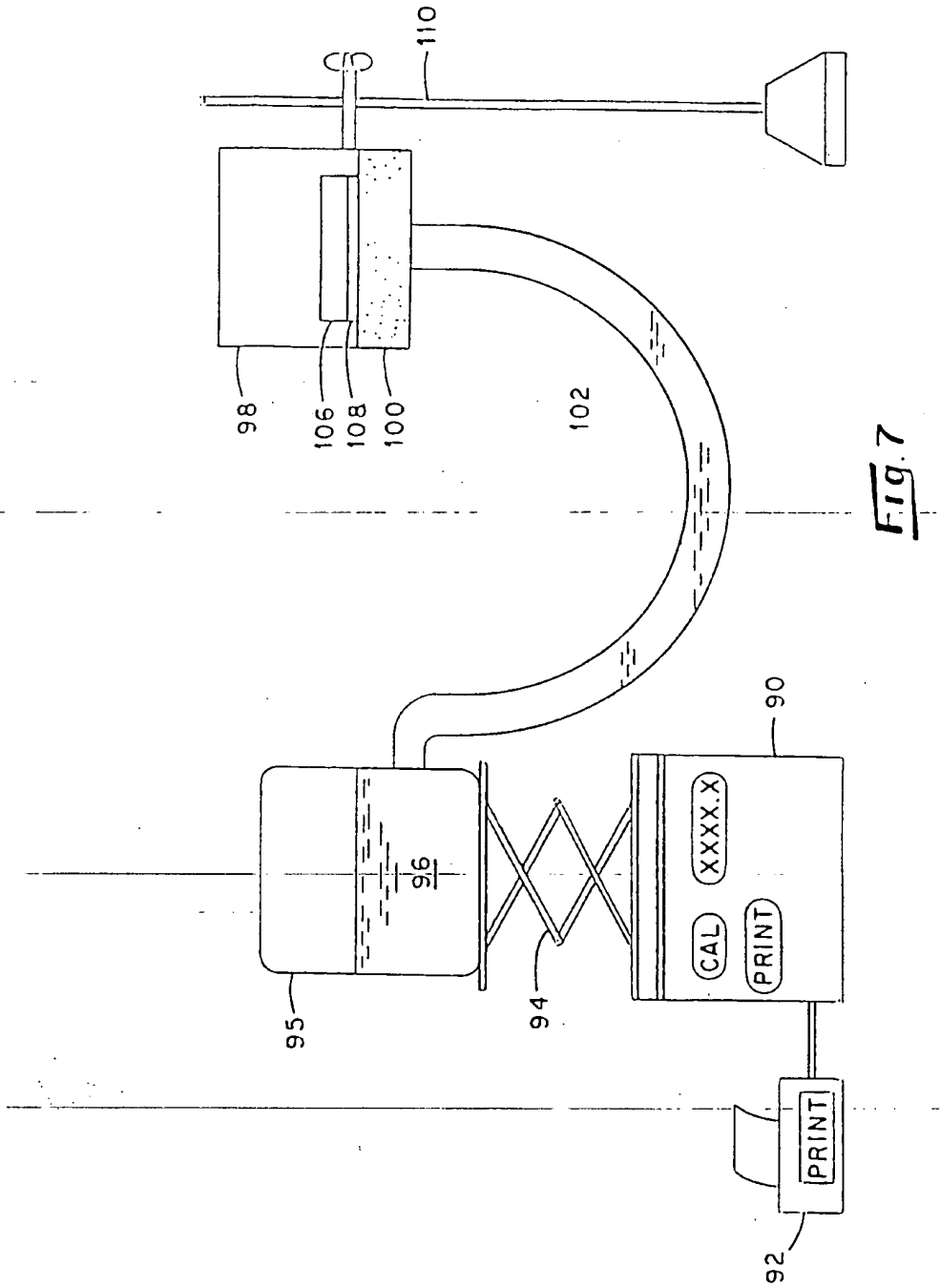
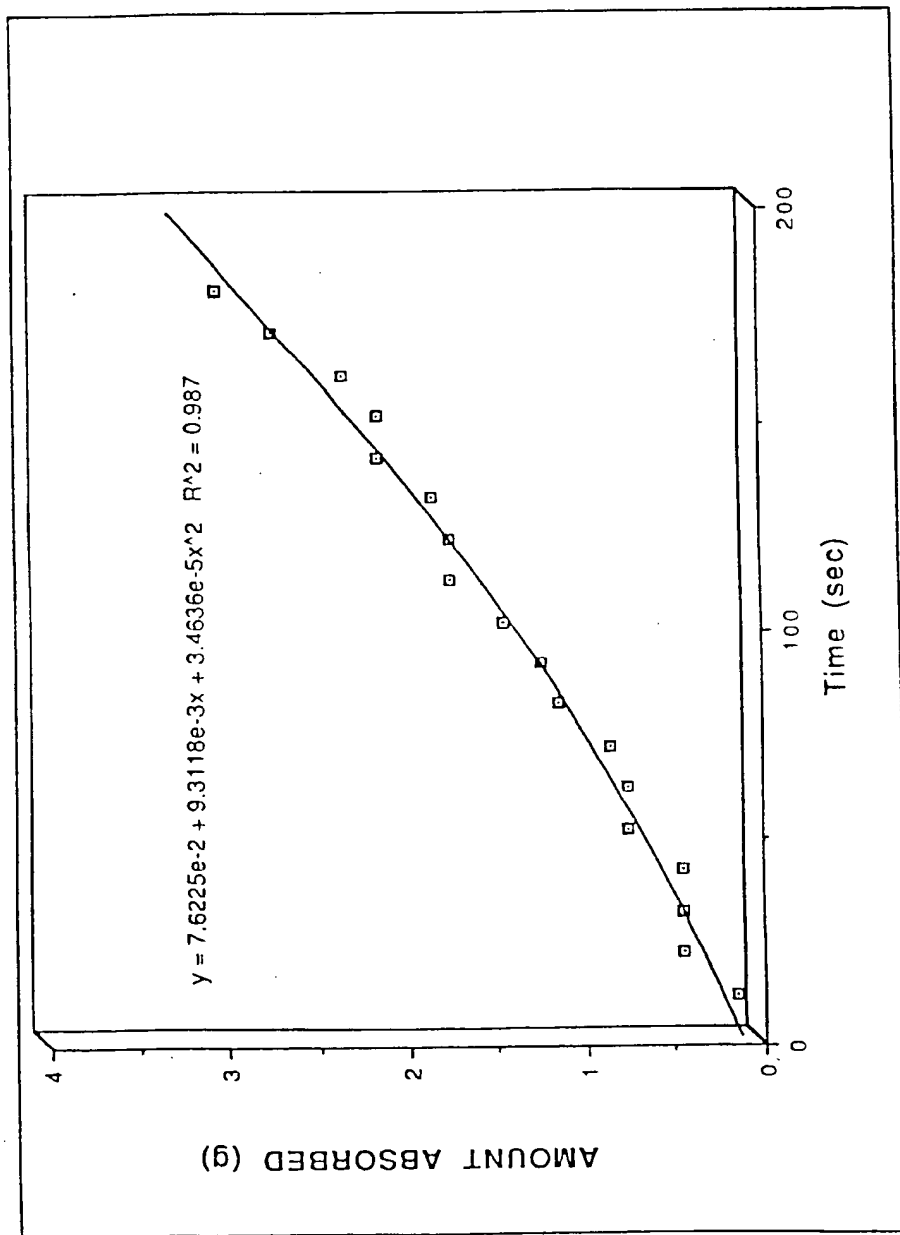
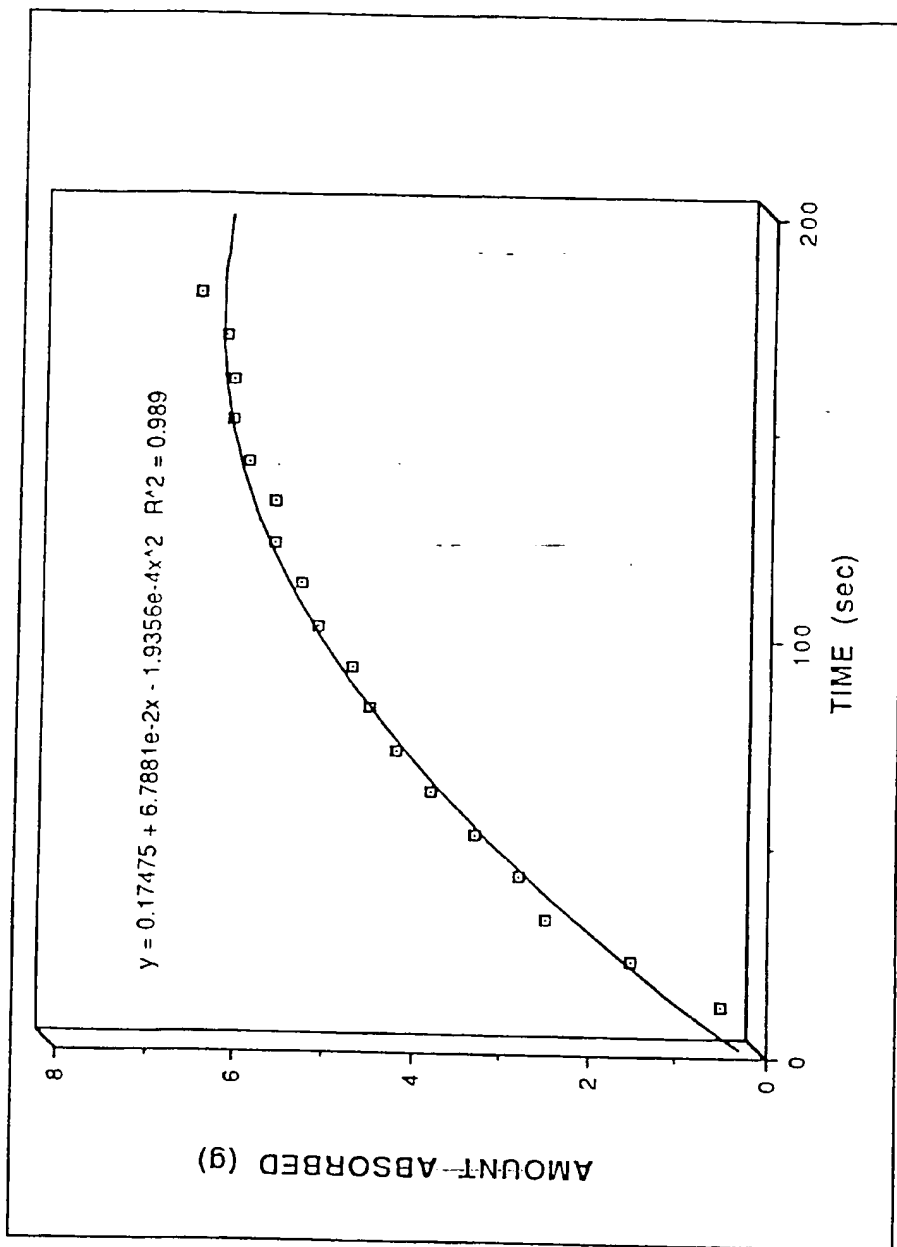

Fig. 7



WICKING RESPONSE CURVE FOR SAMPLE #20

Fig. 8



WICKING RESPONSE CURVE FOR SAMPLE #21

Fig. 9

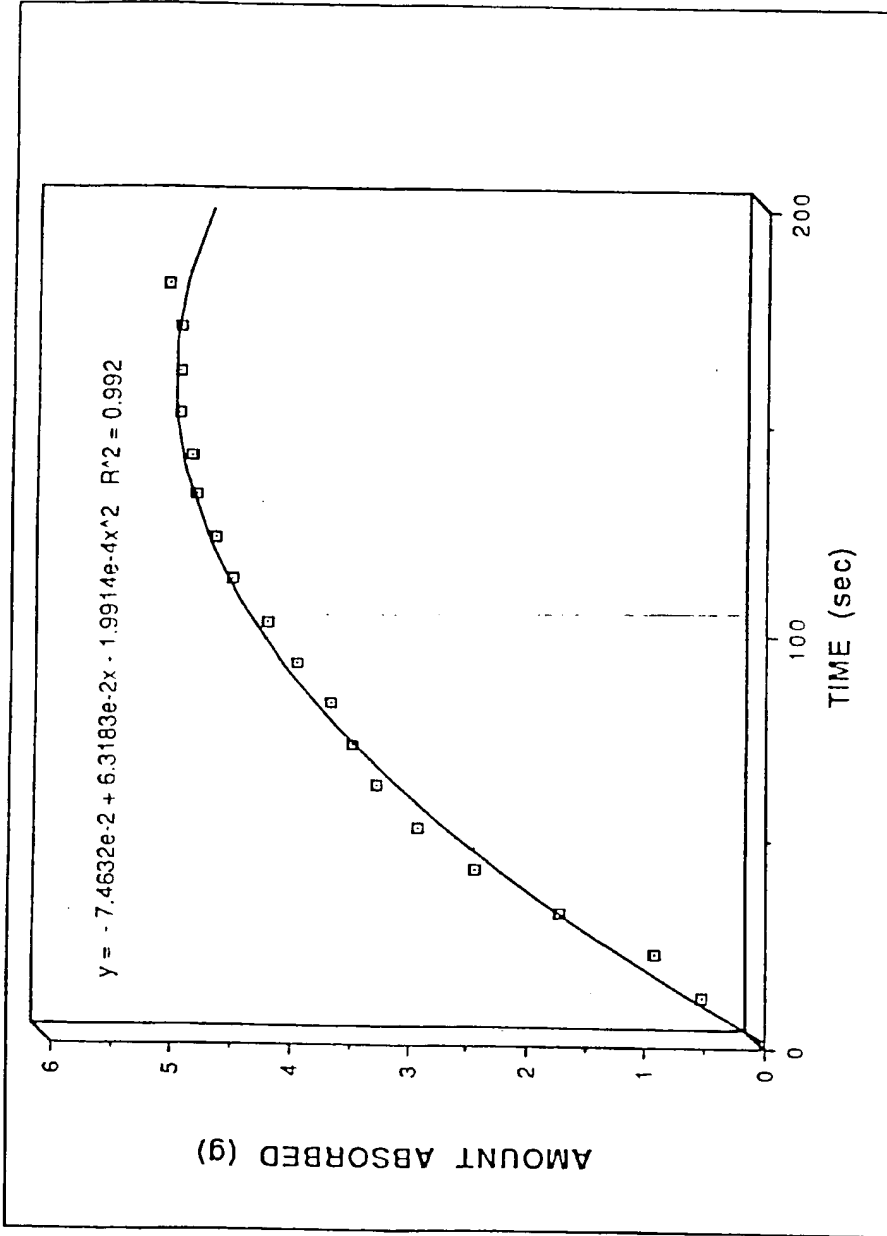

WICKING RESPONSE CURVE FOR SAMPLE #22

Fig. 10

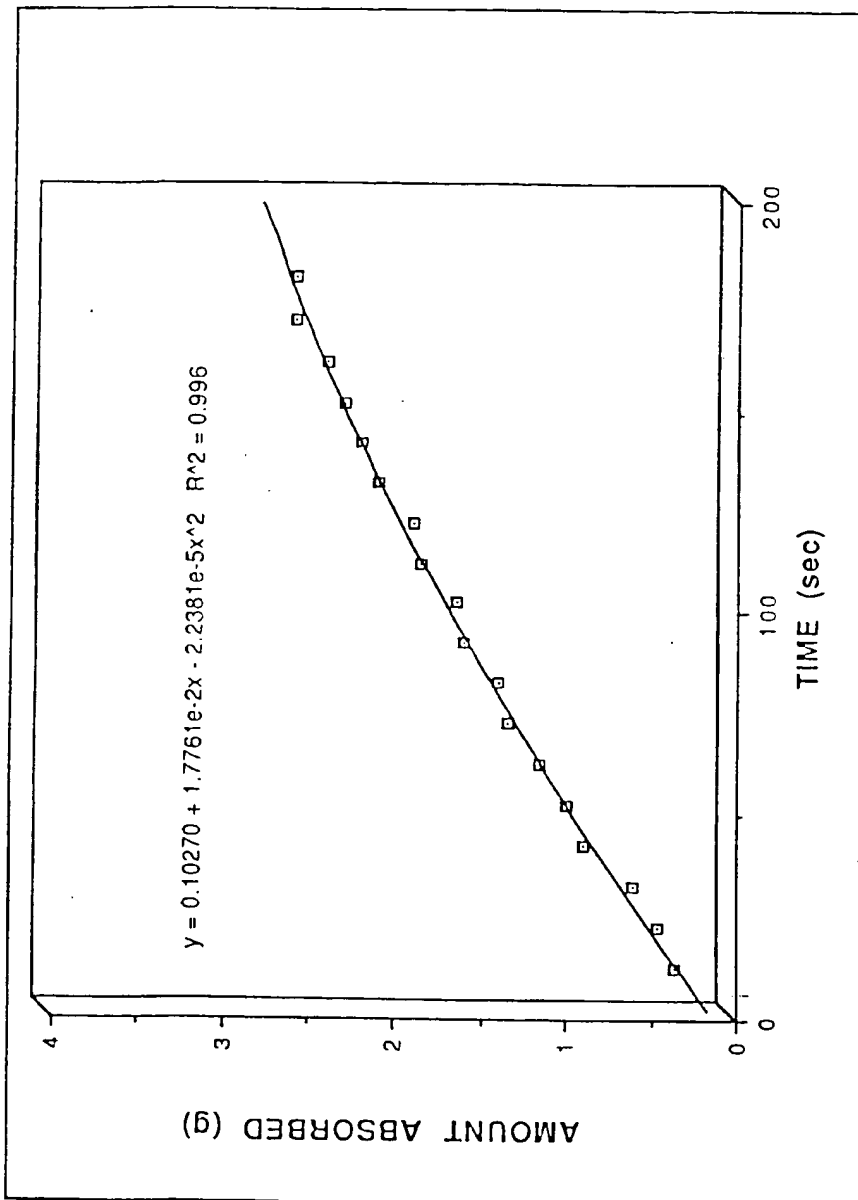

WICKING RESPONSE CURVE FOR SAMPLE #25B

Fig. 11

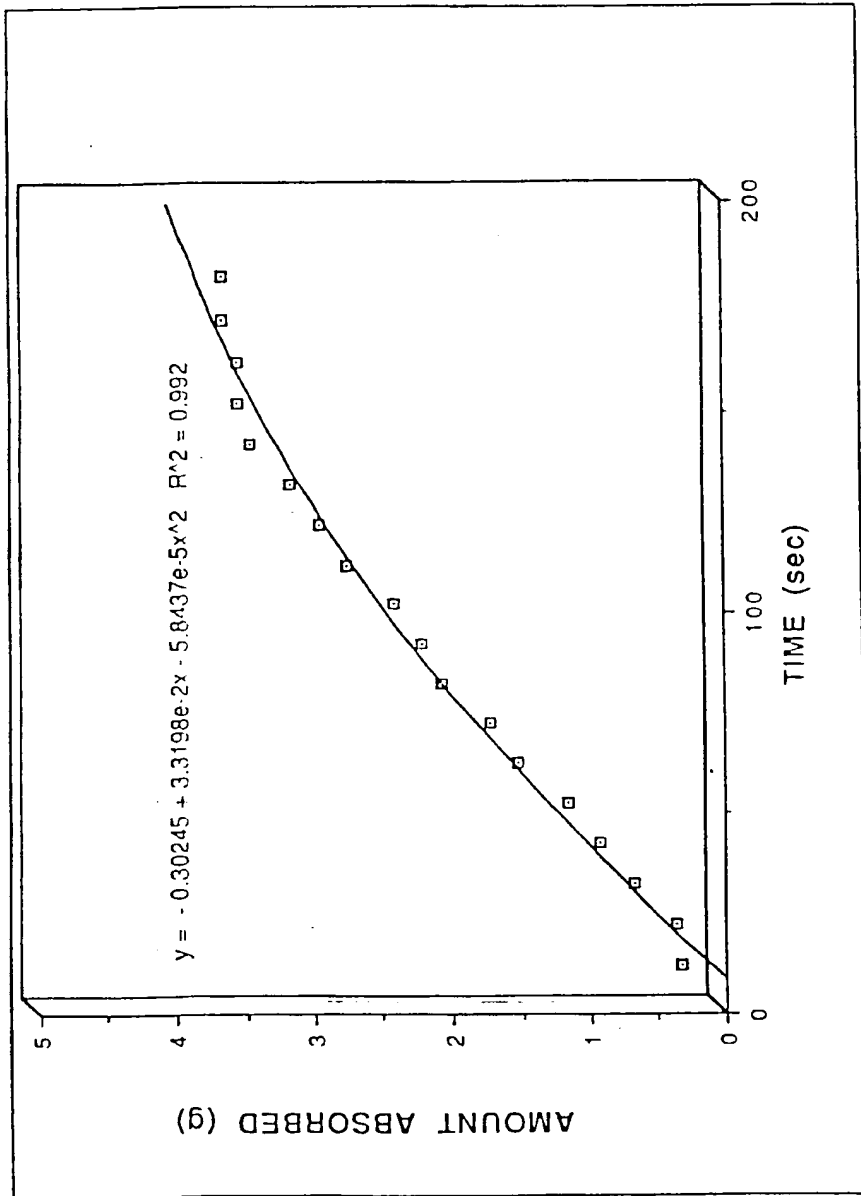

WICKING RESPONSE CURVE FOR SAMPLE #26A

Fig. 12

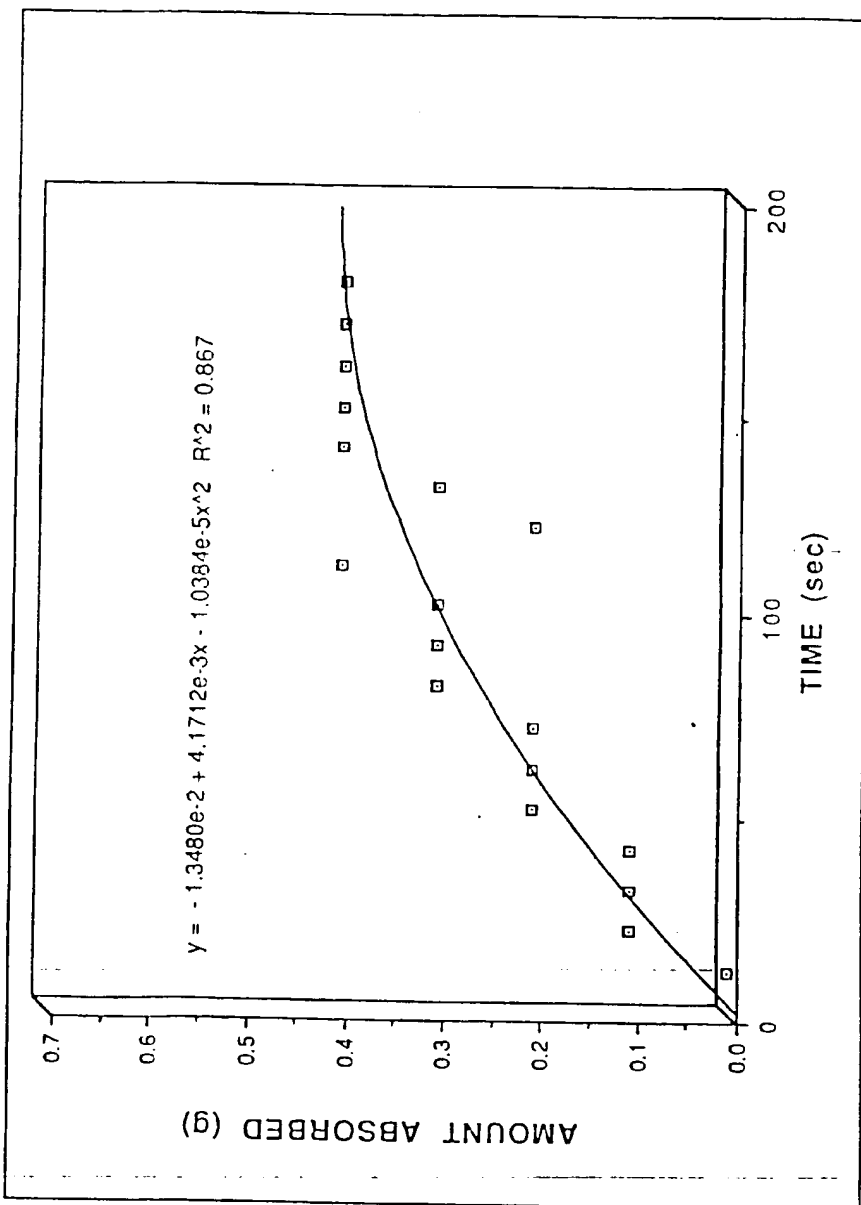

WICKING RESPONSE CURVE FOR SAMPLE #27

Fig. 13

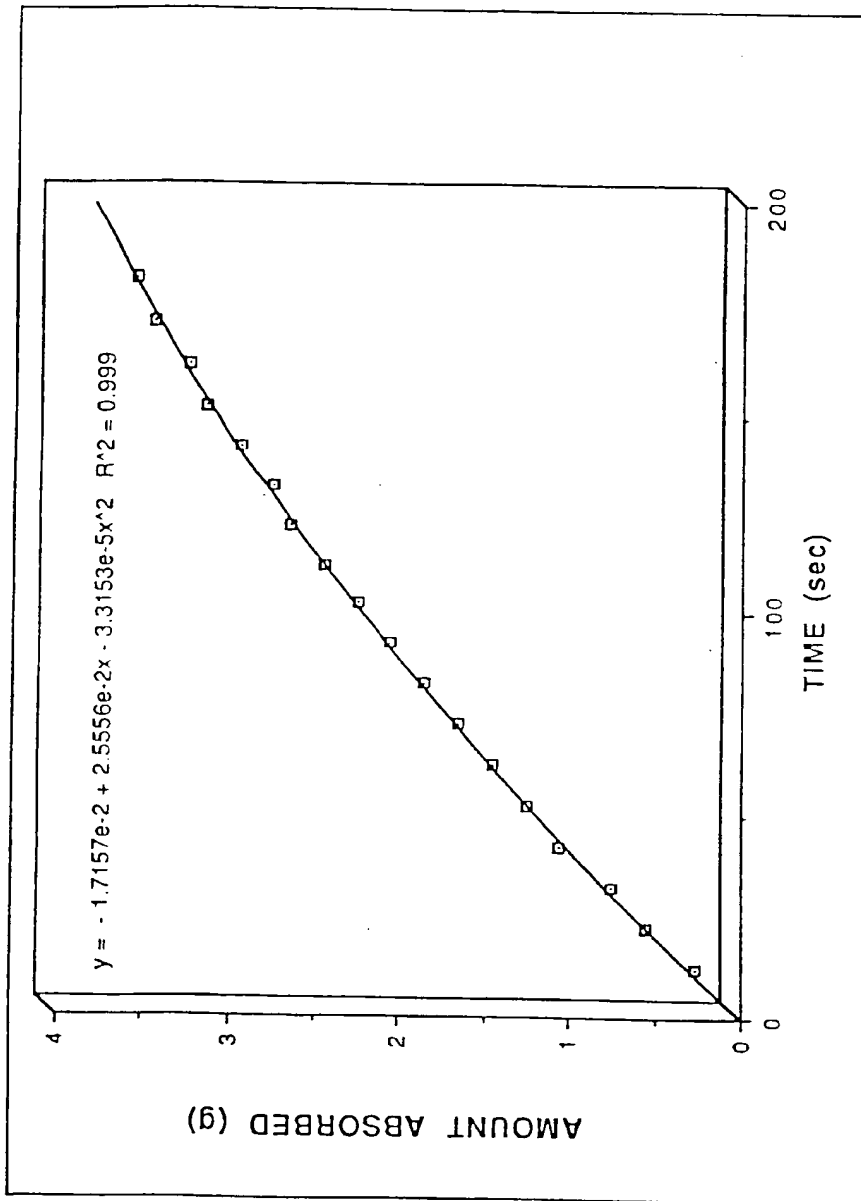

WICKING RESPONSE CURVE FOR SAMPLE #28A

Fig. 14

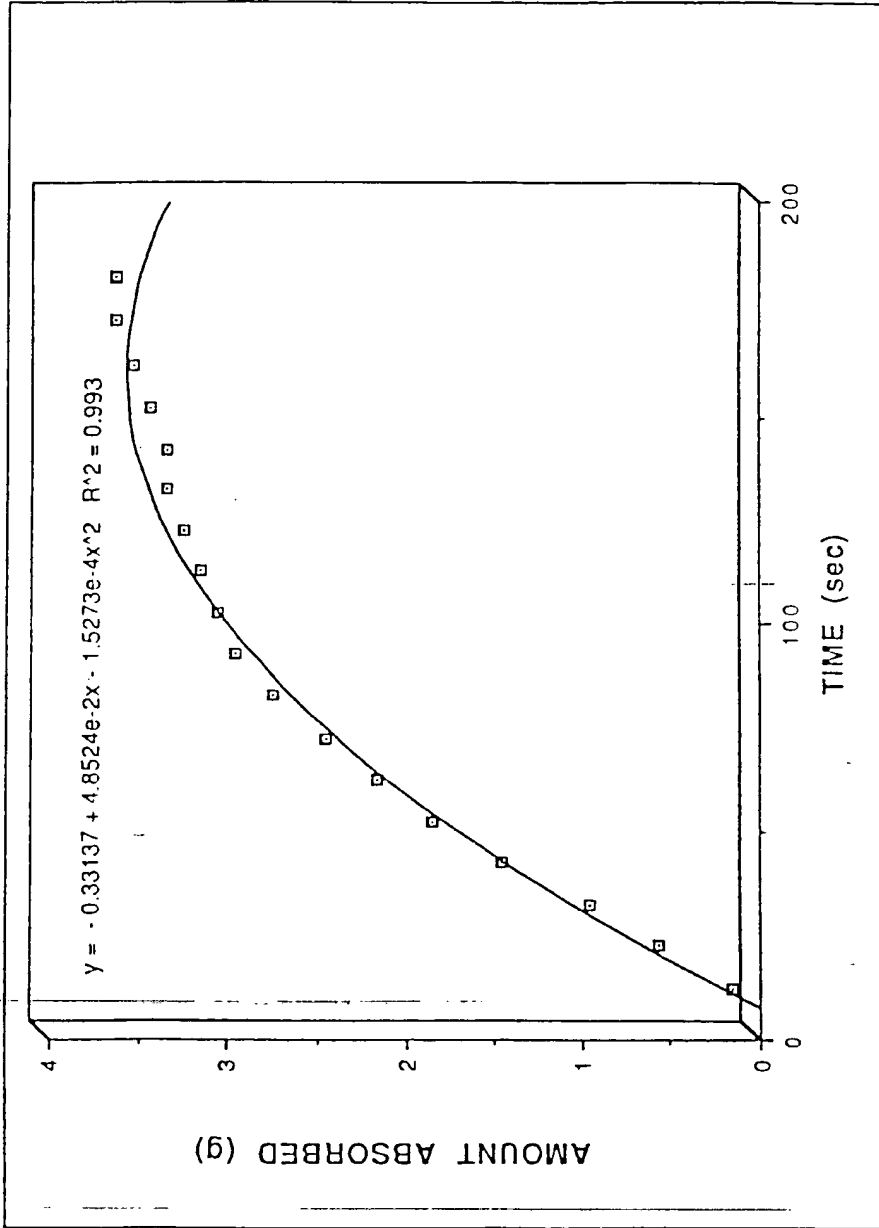

WICKING RESPONSE CURVE FOR SAMPLE #29A

FIG. 15

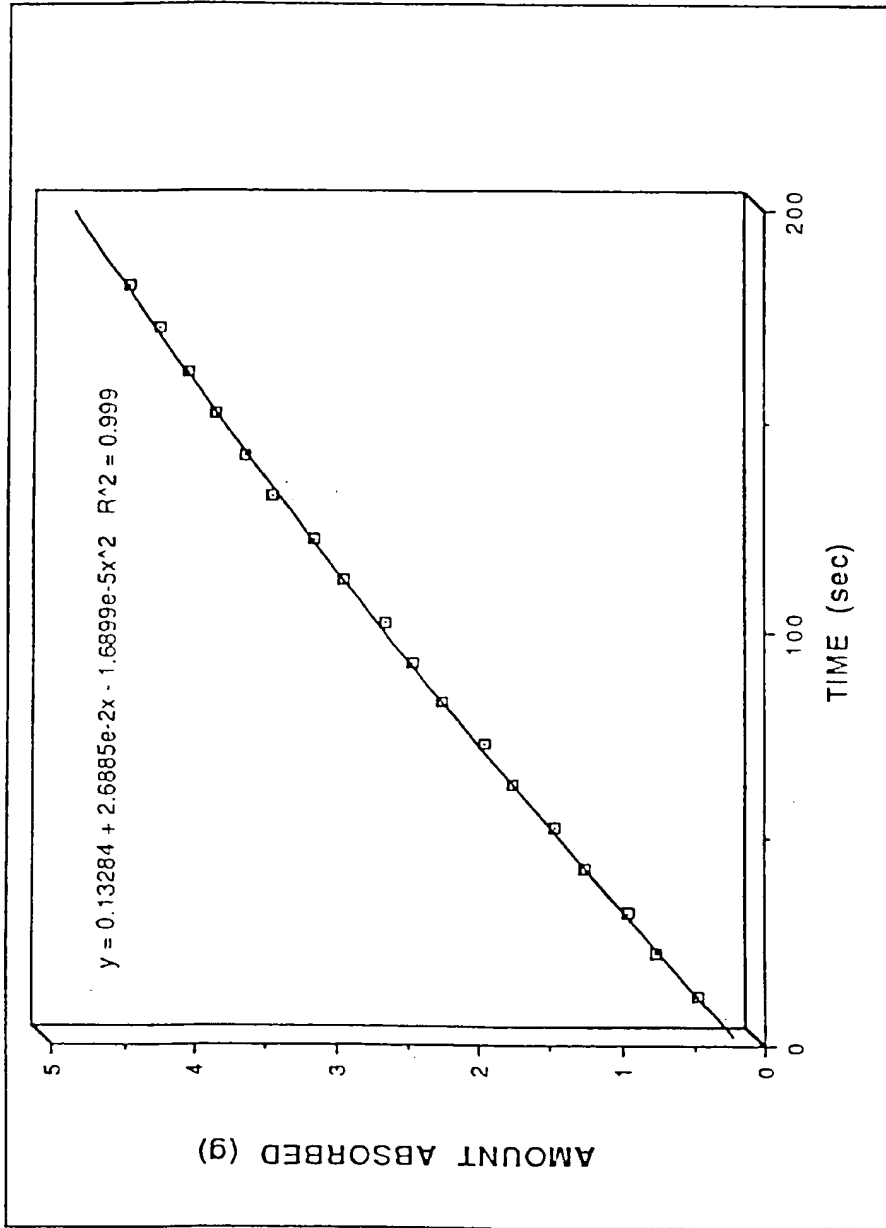

WICKING RESPONSE CURVE FOR SAMPLE #30A

Fig. 16

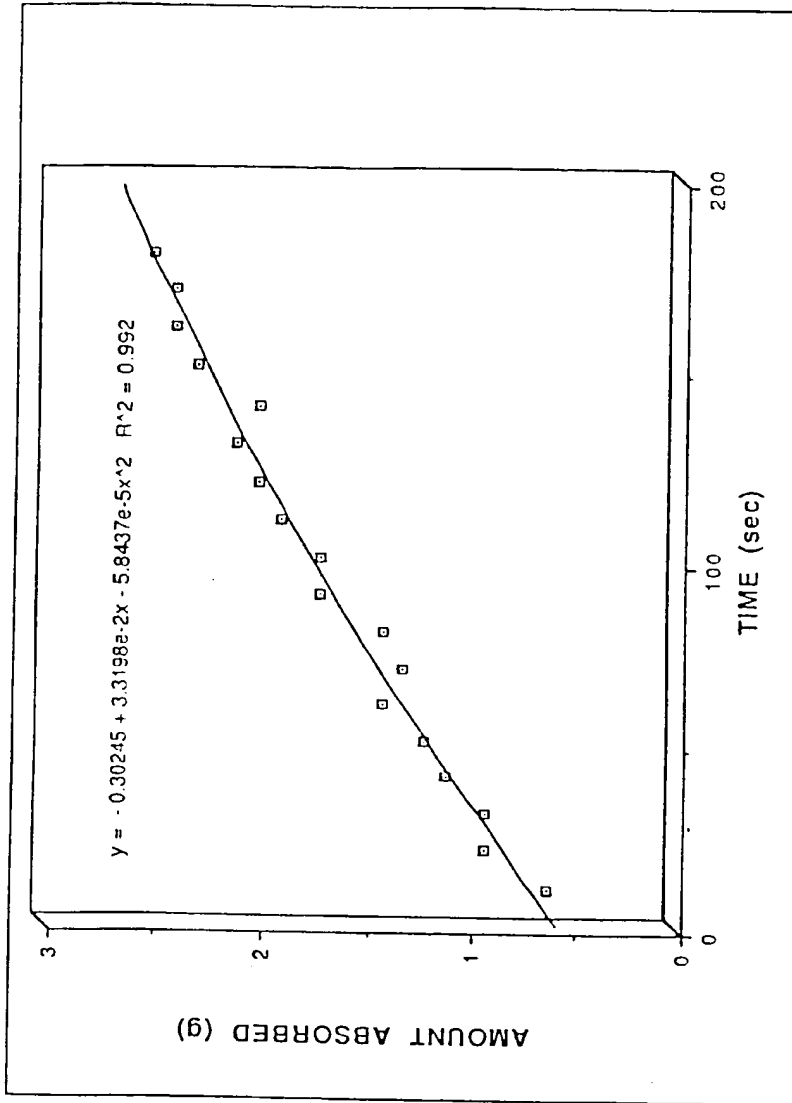

WICKING RESPONSE CURVE FOR SAMPLE #31A

Fig. 17

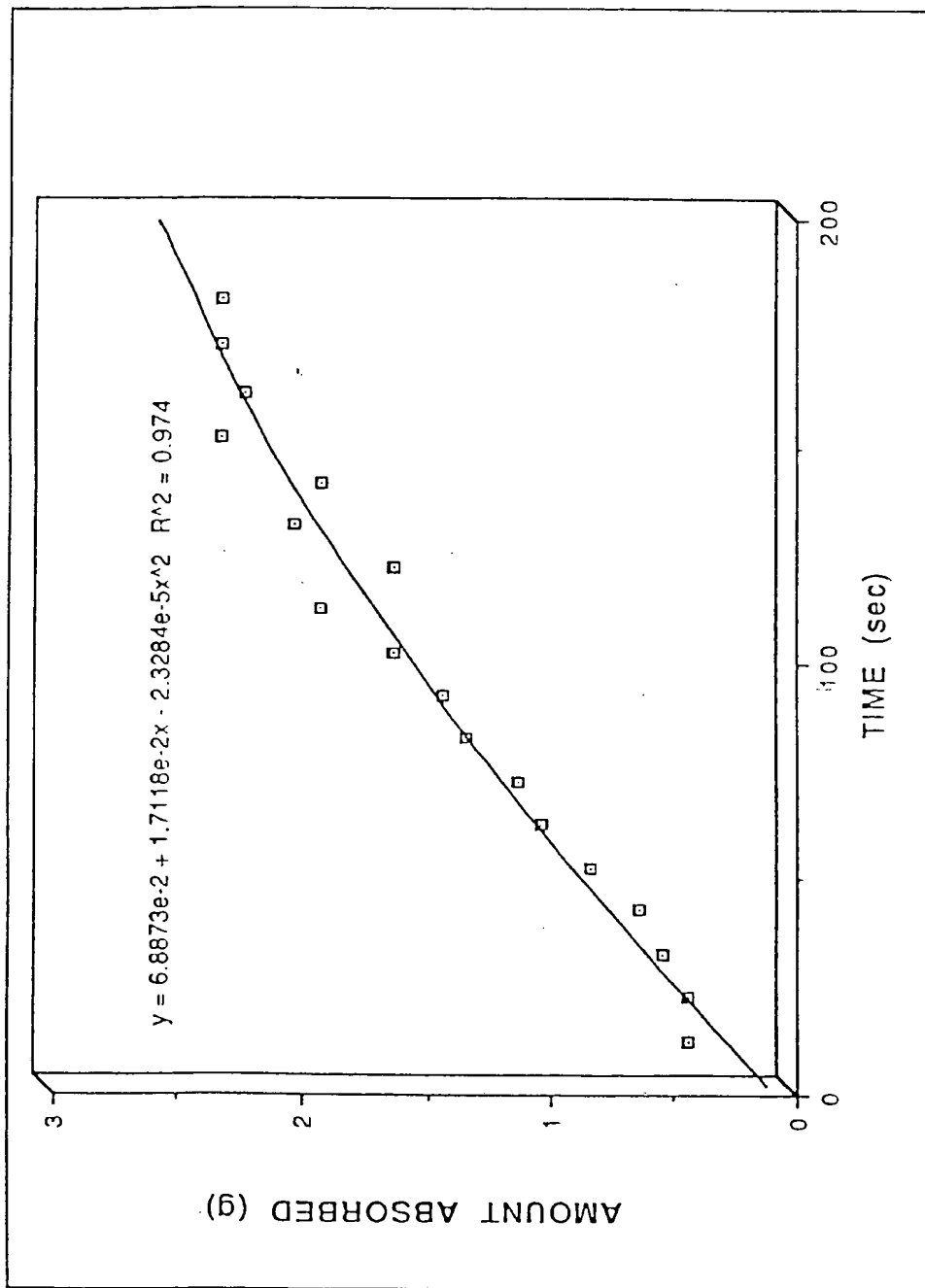

WICKING RESPONSE CURVE FOR SAMPLE #32A

Fig. 18

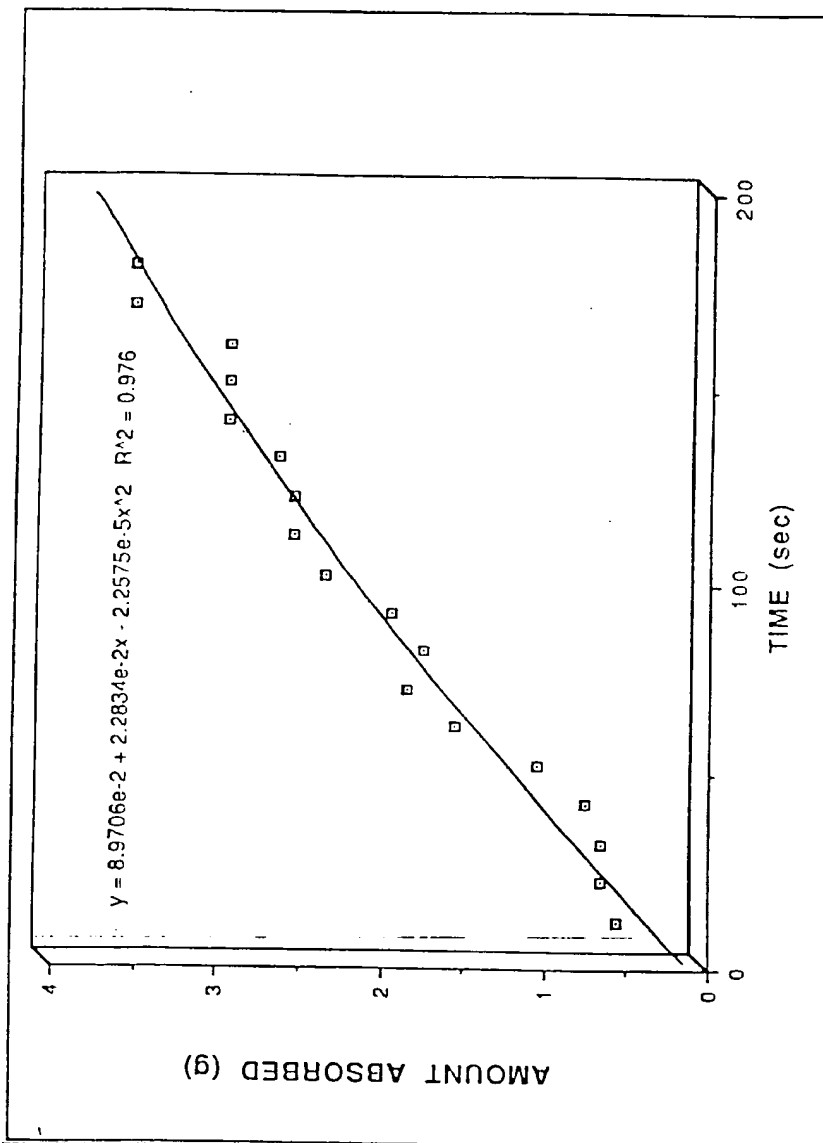

WICKING RESPONSE CURVE FOR SAMPLE #33

Fig. 19

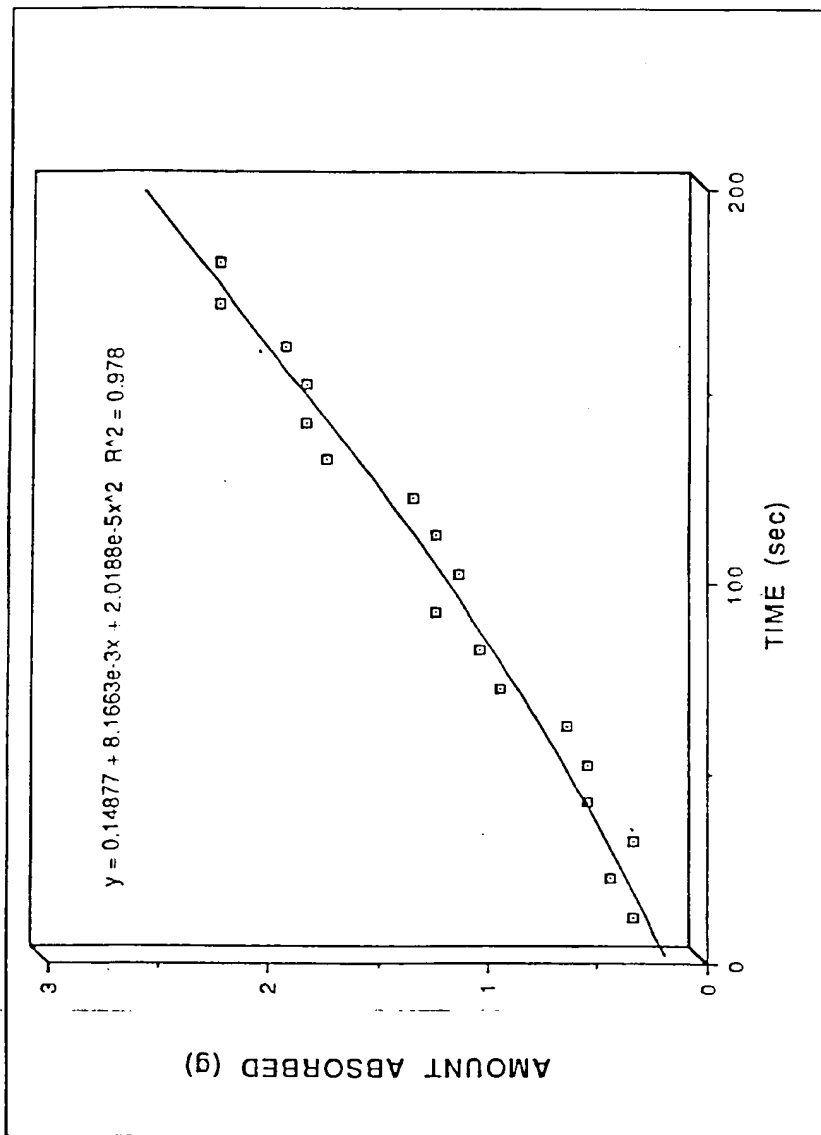

WICKING RESPONSE CURVE FOR SAMPLE #34

Fig. 20

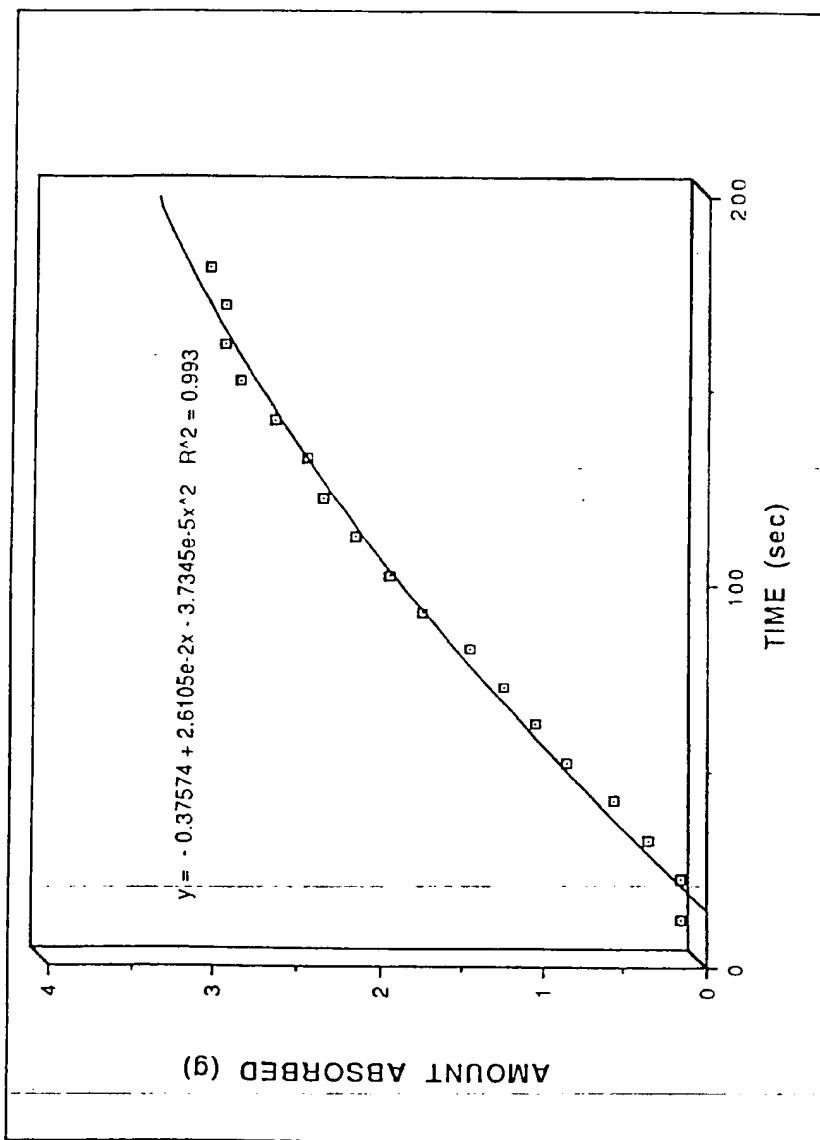

WICKING RESPONSE CURVE FOR SAMPLE #35

Fig. 21

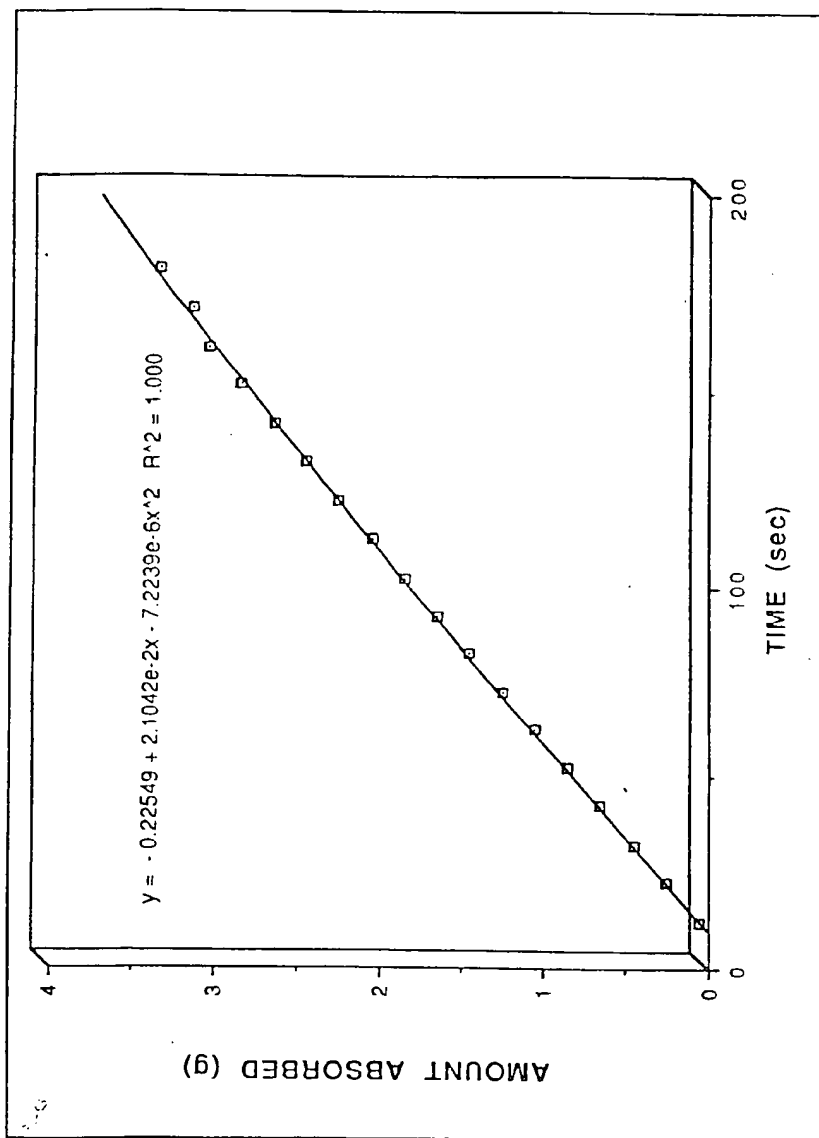

WICKING RESPONSE CURVE FOR SAMPLE #36

FIG. 22

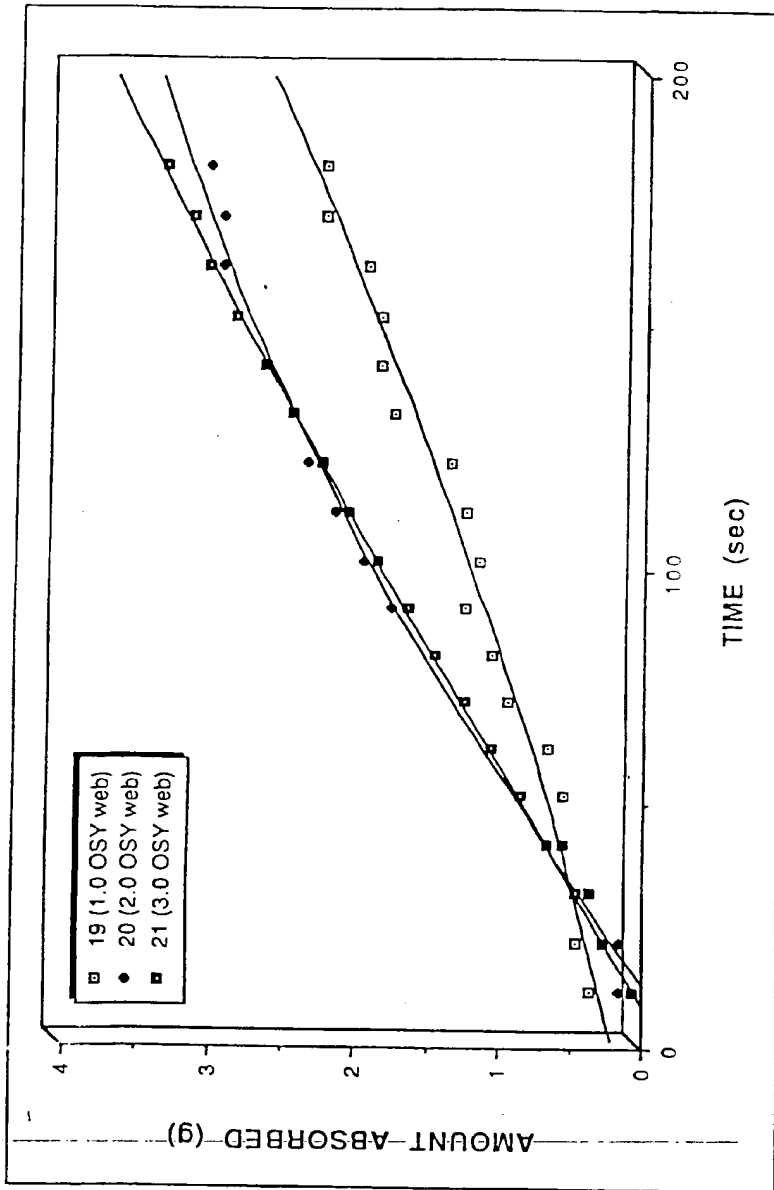

WICKING RESPONSE CURVES FOR FABRICS WITH DIFFERENT RAMIE CORE WEIGHTS

Fig. 23

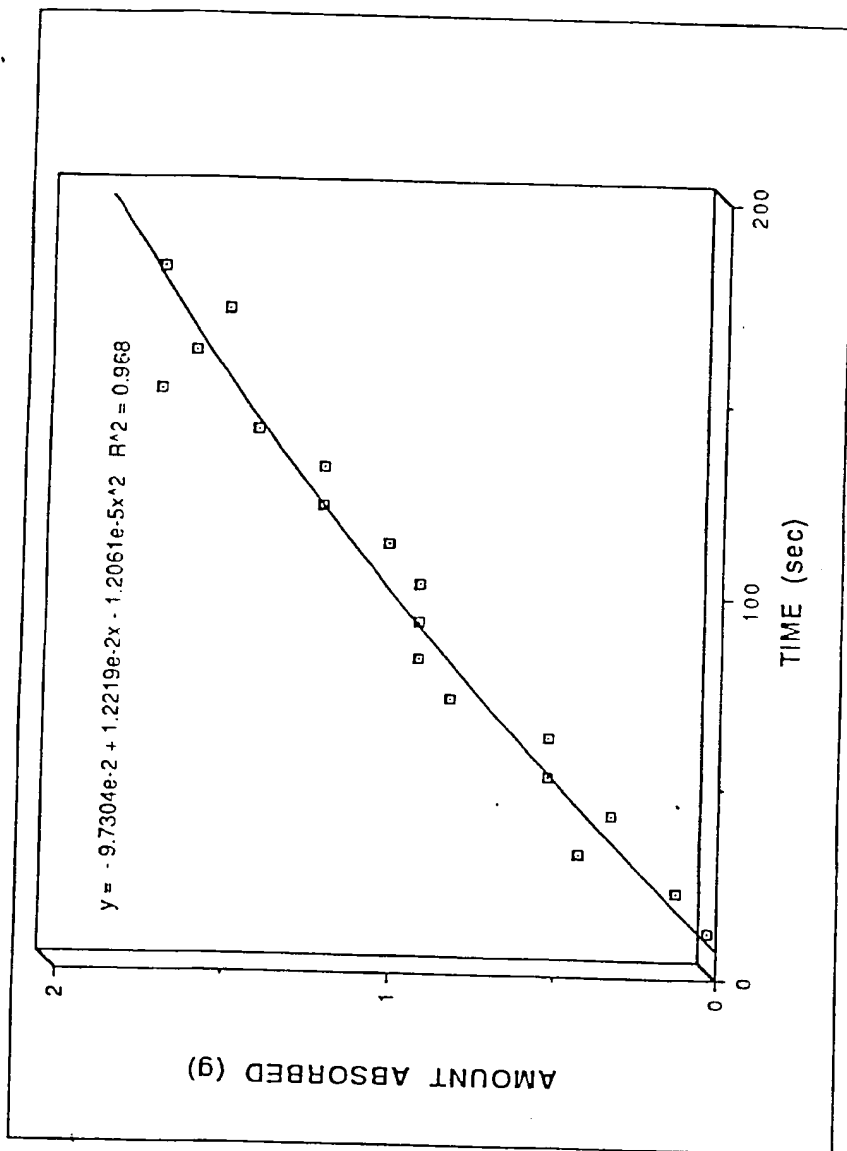

WICKING RESPONSE CURVE FOR SAMPLE #37

Fig. 24

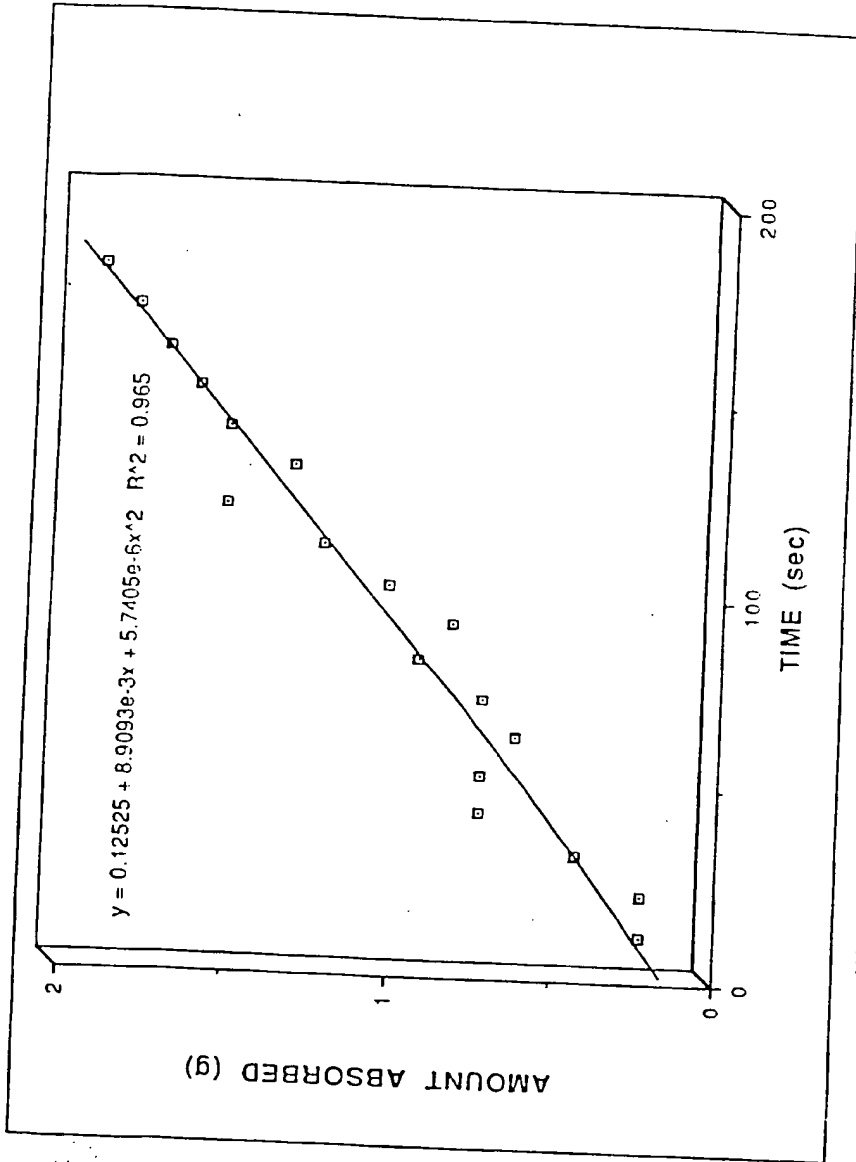

WICKING RESPONSE CURVE FOR SAMPLE #38

Fig. 25

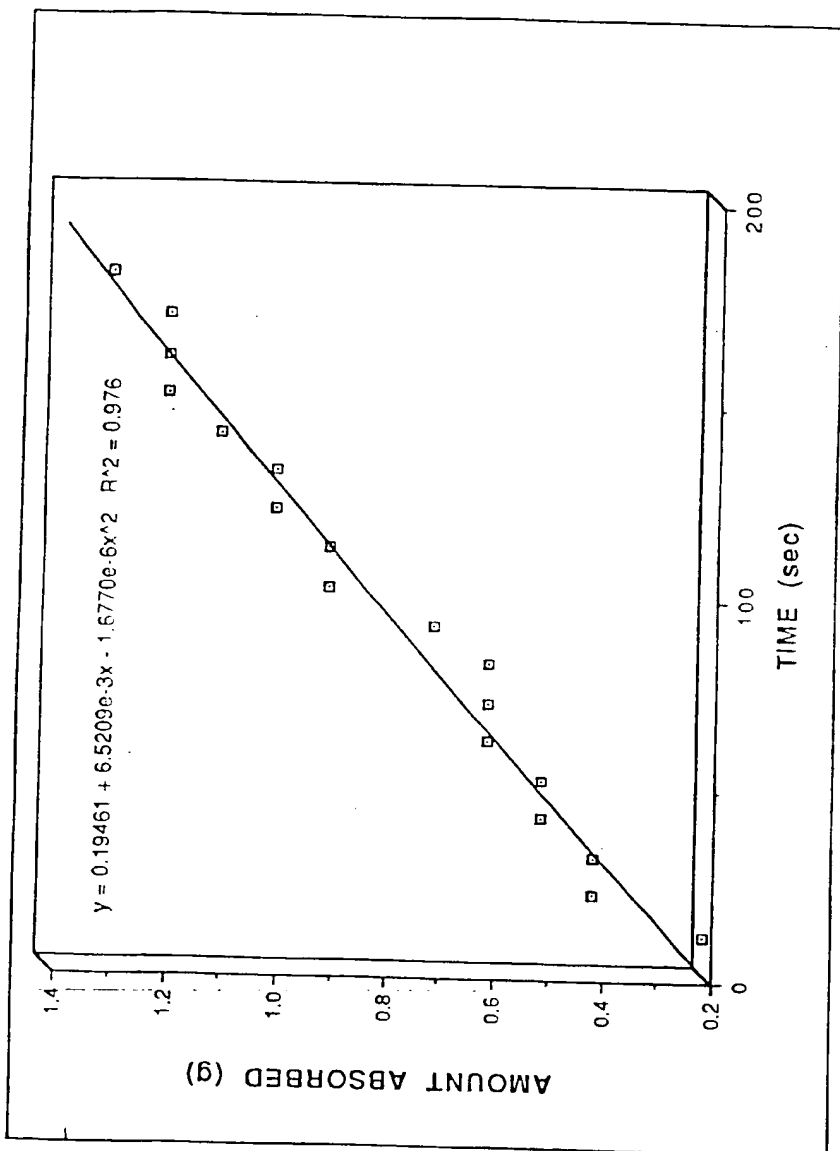

WICKING RESPONSE CURVE FOR SAMPLE #39

Fig. 26

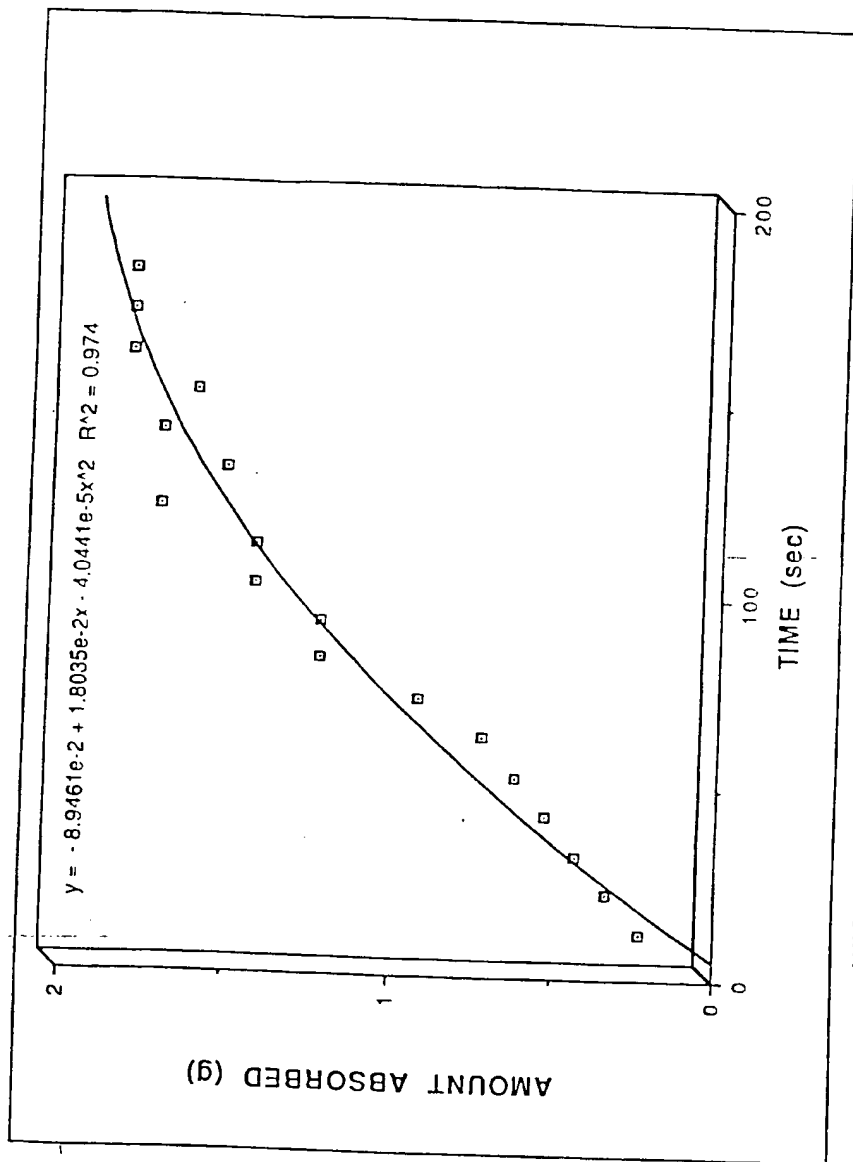

WICKING RESPONSE CURVE FOR SAMPLE #40

Fig. 27

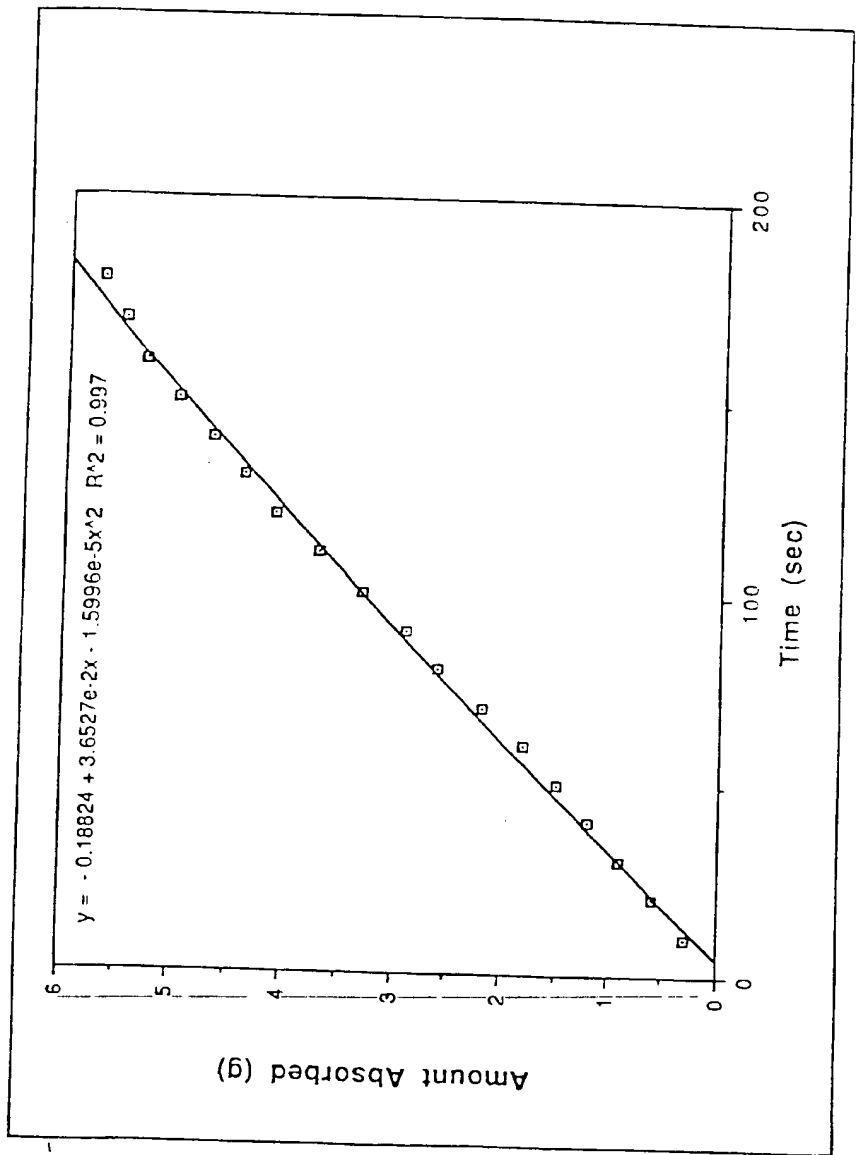

Wicking Response Curve for Sample #41

FIG. 28

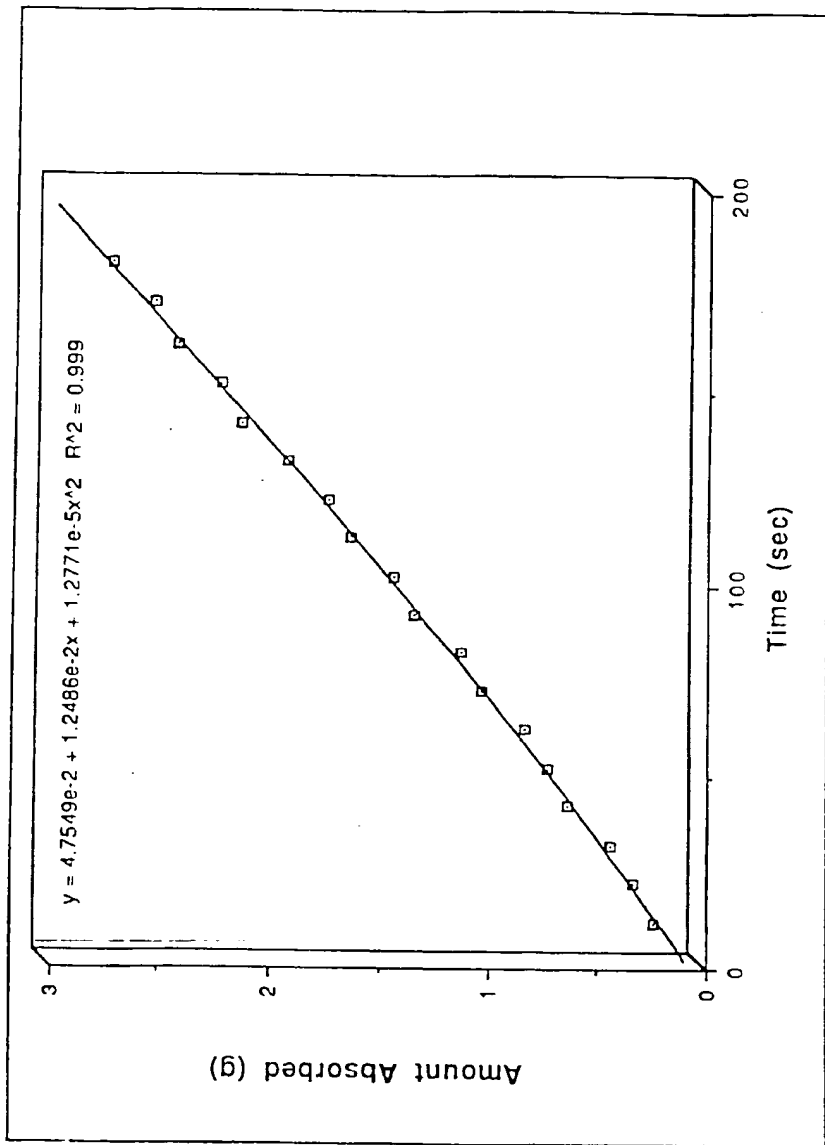

Wicking Response Curve for Sample #42

Fig. 29

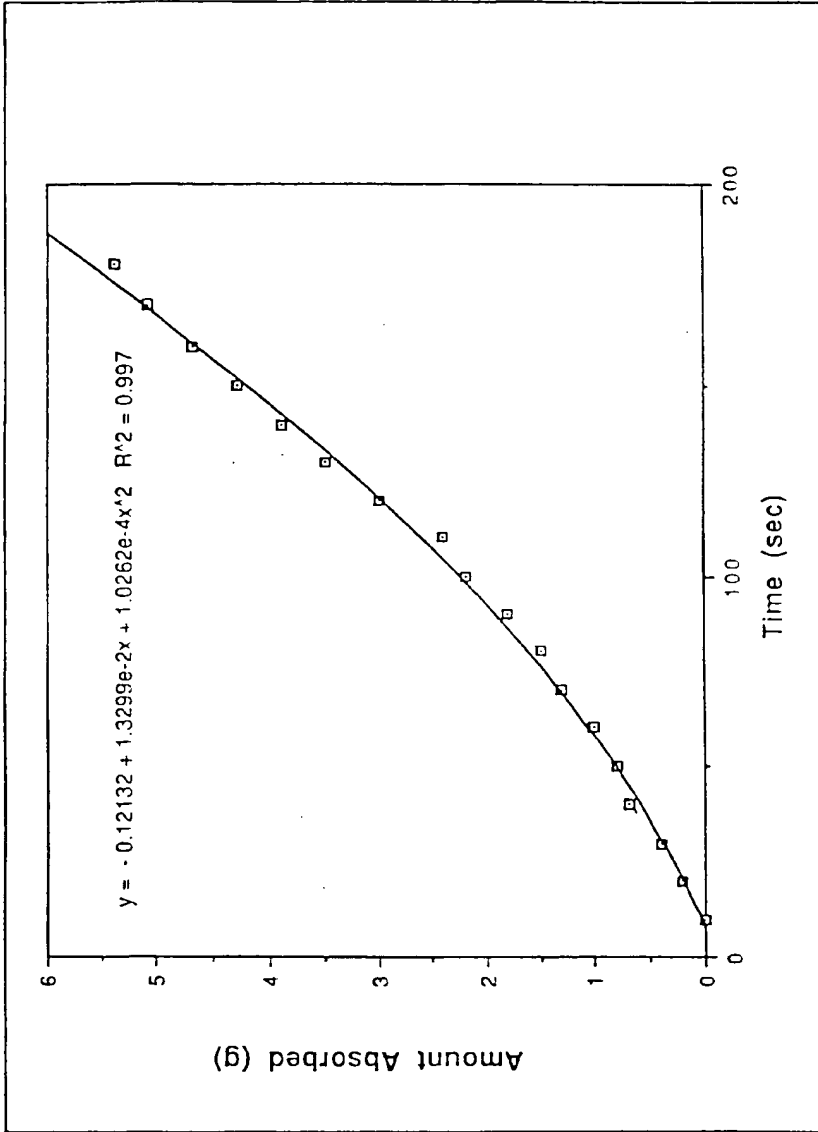

Wicking Response Curve for Sample #43

Fig. 30

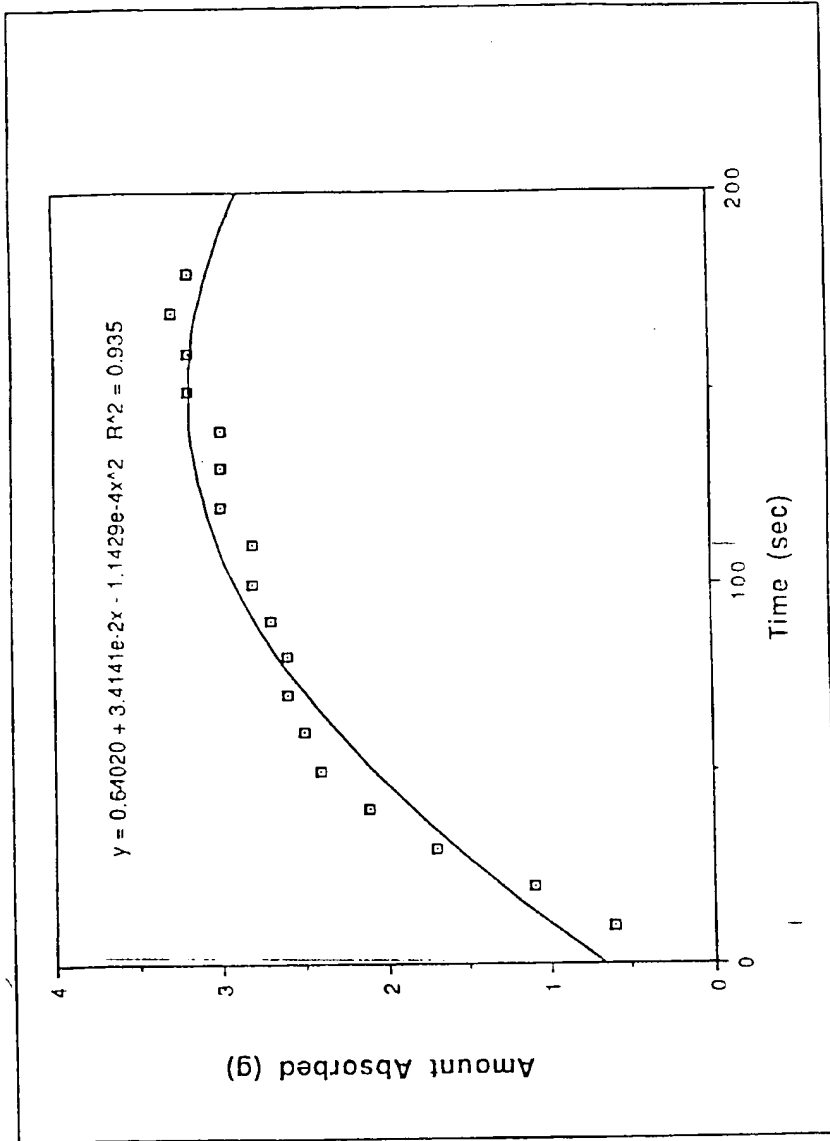

Wicking Response Curve for Sample #44

Fig. 31

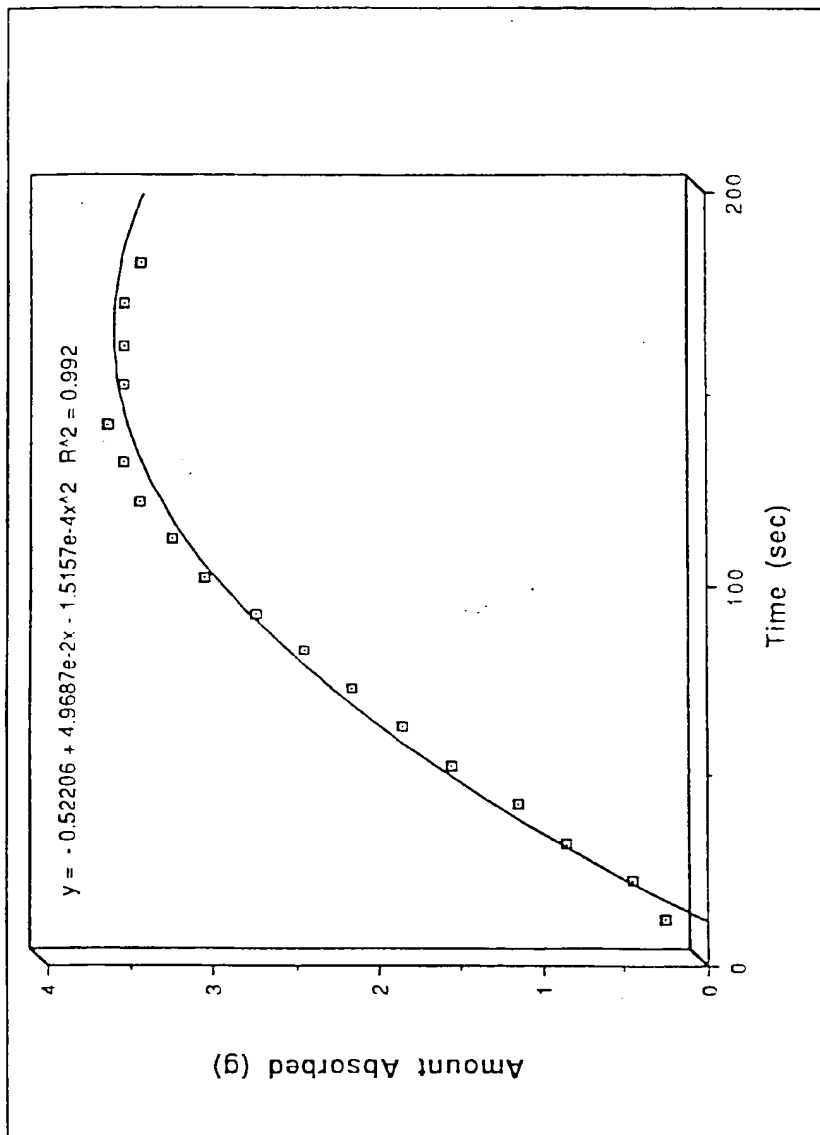

Wicking Response Curve for Sample #45

FIG. 32

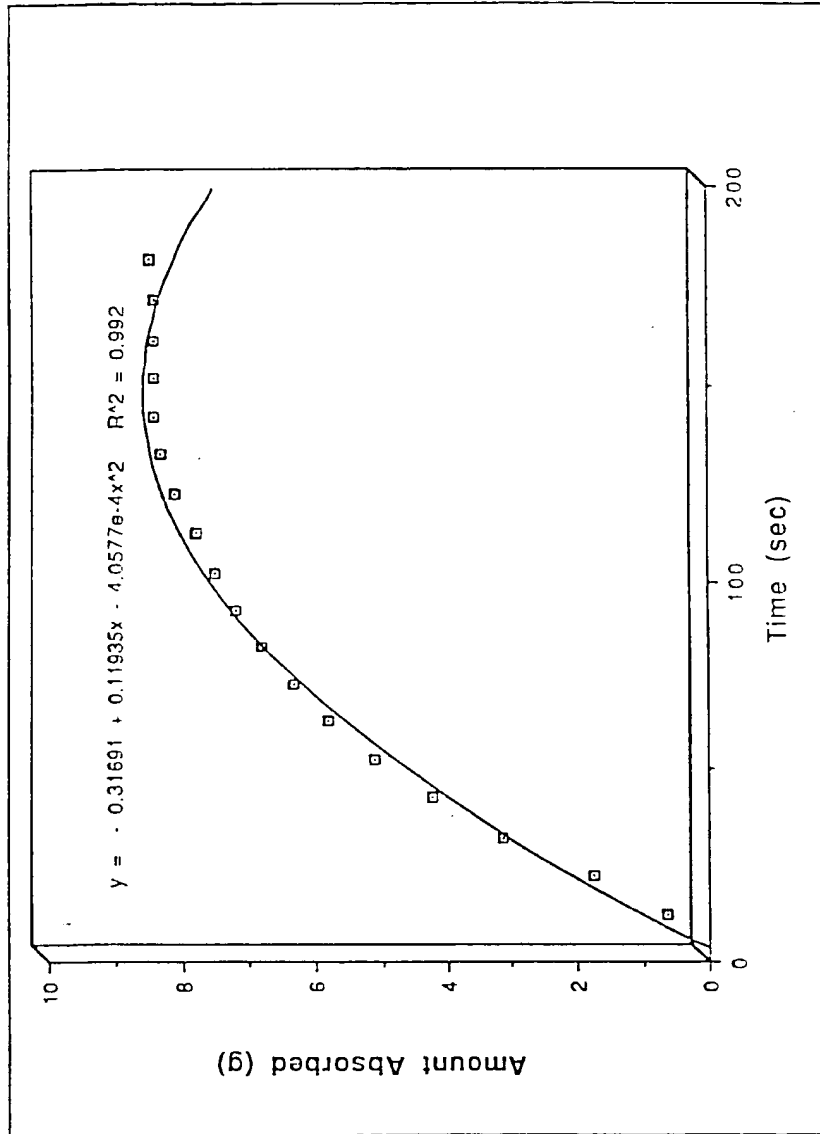

Wicking Response Curve for Sample #46

Fig. 33

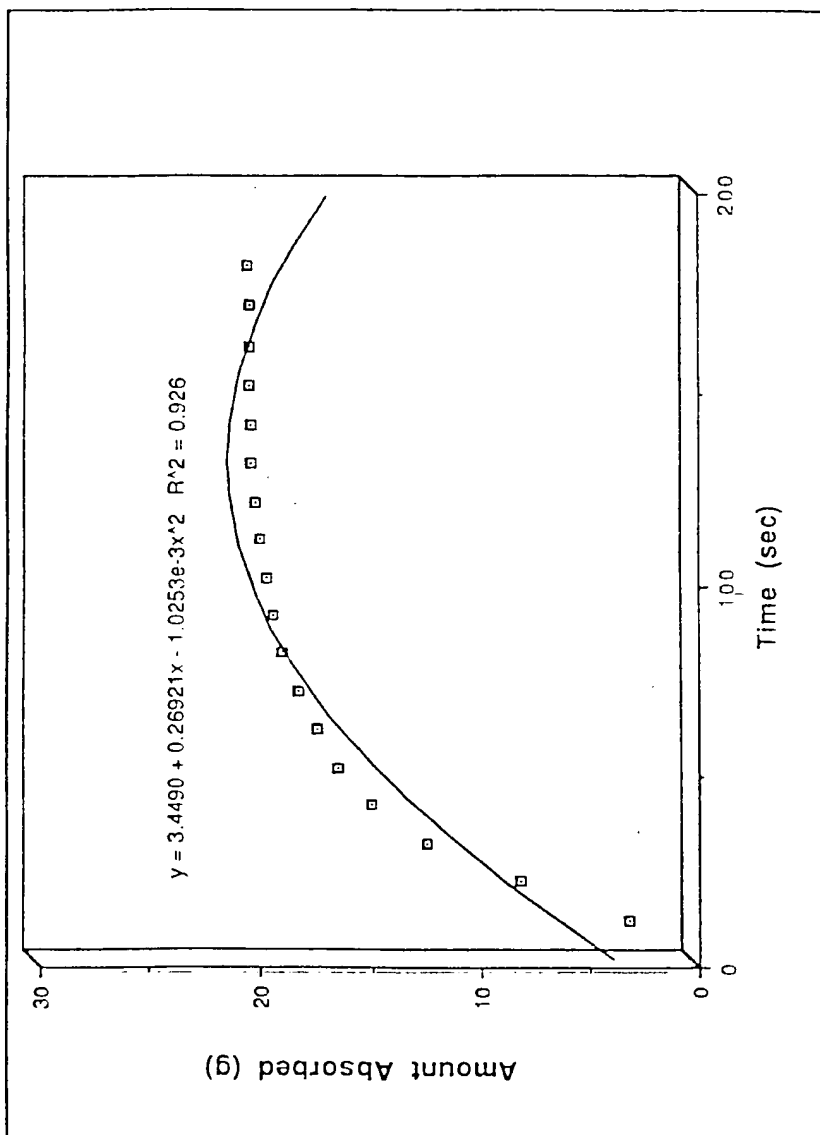

Wicking Response Curve for Sample #47

Fig. 34

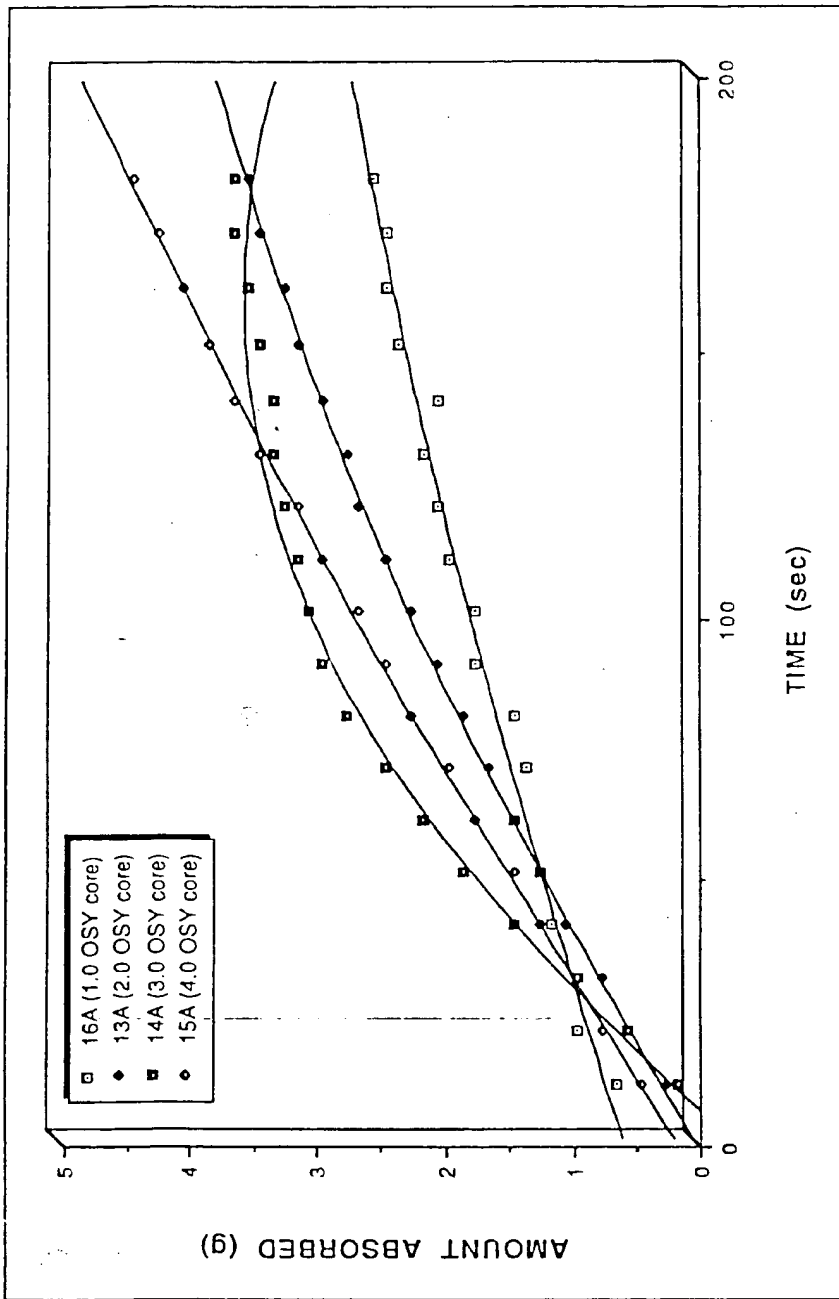

WICKING RESPONSE CURVES FOR FABRICS WITH DIFFERENT COTTON CORE WEIGHT

Fig. 35

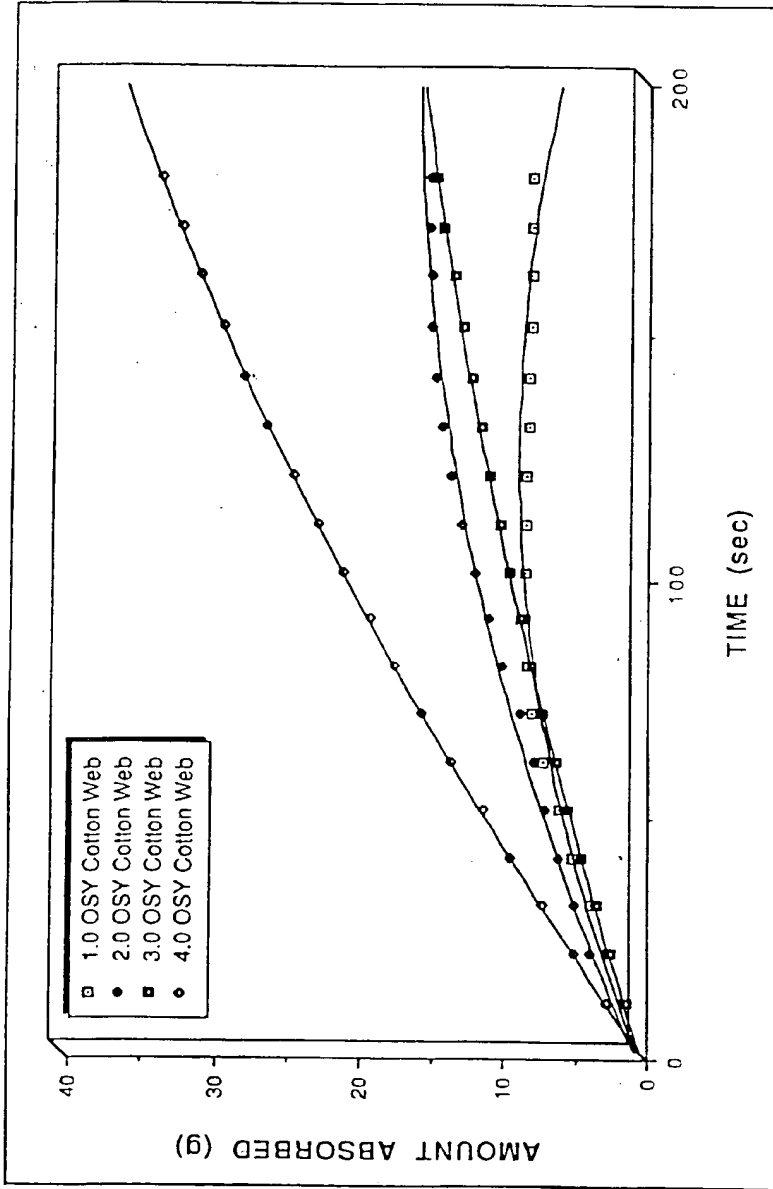

WICKING RESPONSE CURVES FOR 100% COTTON WEBS OF DIFFERENT WEIGHTS WITHOUT BEING LAMINATED TO MELT BLOWN OR SPUNBOND WEBS

Fig. 36

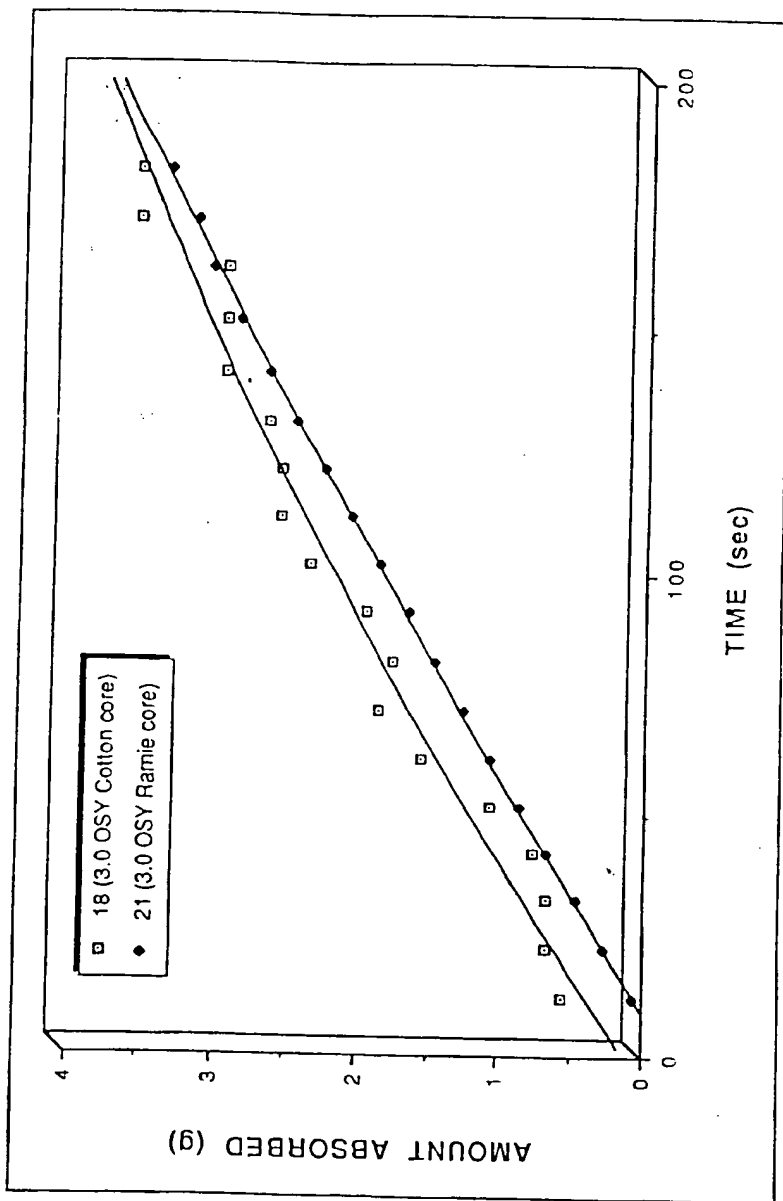

WICKING RESPONSE CURVES FOR FABRICS WITH COTTON AND RAMIE CORE COMPONENTS

Fig. 37

INTERNATIONAL SEARCH REPORT

International application No.
PCT/US93/01783

A. CLASSIFICATION OF SUBJECT MATTER IPC(5) :B32B 5/26, 27/02, 27/06, 27/12 US CL :428/286, 298, 302 According to International Patent Classification (IPC) or to both national classification and IPC		
B. FIELDS SEARCHED Minimum documentation searched (classification system followed by classification symbols) U.S. : 428/286, 298, 302 Documentation searched other than minimum documentation to the extent that such documents are included in the fields searched Electronic data base consulted during the international search (name of data base and, where practicable, search terms used)		
C. DOCUMENTS CONSIDERED TO BE RELEVANT		
Category*	Citation of document, with indication, where appropriate, of the relevant passages	Relevant to claim No.
Y	US, A, 4,355,066 (NEWMAN) 19 OCTOBER 1982. See column 2, lines 1-27.	1-6
Y	US, A, 4,885,202 (LLOYD) 05 DECEMBER 1989. See column 1, lines 18-51.	1-6
Y	US, A, 4,950,531 (RADWANSKI) 21 AUGUST 1990. See entire disclosure.	1-6
<input type="checkbox"/> Further documents are listed in the continuation of Box C. <input type="checkbox"/> See patent family annex.		
* Special categories of cited documents:		
A	document defining the general state of the art which is not considered to be part of particular relevance	*T* later document published after the international filing date or priority date and not in conflict with the application but cited to understand the principle or theory underlying the invention
E	earlier document published on or after the international filing date	*X* document of particular relevance; the claimed invention cannot be considered novel or cannot be considered to involve an inventive step when the document is taken alone
L	document which may throw doubts on priority claim(s) or which is cited to establish the publication date of another citation or other special reason (as specified)	*Y* document of particular relevance; the claimed invention cannot be considered to involve an inventive step when the document is combined with one or more other such documents, such combination being obvious to a person skilled in the art
O	document referring to an oral disclosure, use, exhibition or other means	*Z* document member of the same patent family
P	document published prior to the international filing date but later than the priority date claimed	
Date of the actual completion of the international search— 21 APRIL 1993		Date of mailing of the international search report— 19 MAY 1993
Name and mailing address of the ISA/US Commissioner of Patents and Trademarks Box PCT Washington, D.C. 20231 Facsimile No. NQT APPLICABLE		Authorized officer CHRISTOPHER BROWN <i>Christopher Brown</i> Telephone No. (703) 308-2351 <i>for</i>

Form PCT/ISA/210 (second sheet)(July 1992)*